

REV
SH
266
DWG NO

REVISIONS			
REV	DESCRIPTION	DATE	APPROVED

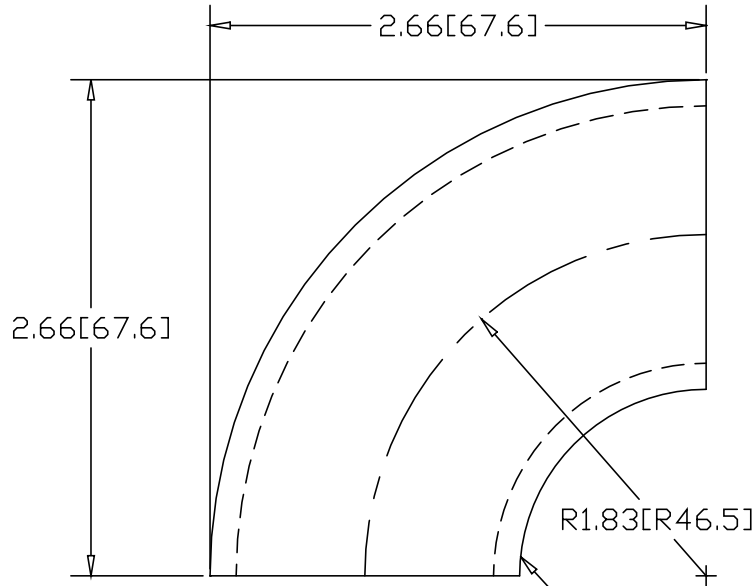

NOTE: UNWELDED SEAM
ALONG INSIDE RADIUS

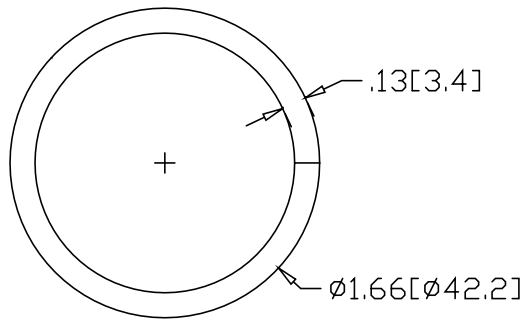

INCHES [MILLIMETERS]

ALTERNATE MATERIAL	PART NUMBER
.125 (3003) ALUMINUM ASTM B209	290
10 GA. (304) STAINLESS STEEL ASTM A240	315

PART NAME		1-1/4" PIPE 1" I.R. X 90° ELL					
MATERIAL		10 GA. HRP&D STEEL ASTM A569					
DATE	04/03/00	 R & B WAGNER, INC.					
DRAWN BY	RJF						
FINISH	MILL						
SIZE	A	WEIGHT	.54 LBS	PART NUMBER	266	REV	