

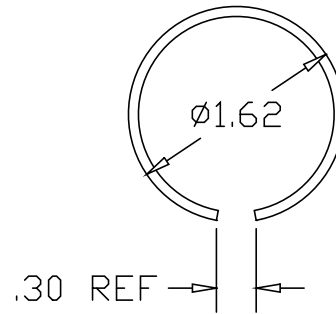

REV  
SH  
1222  
DWG NO

REVISIONS			
REV	DESCRIPTION	DATE	APPROVED

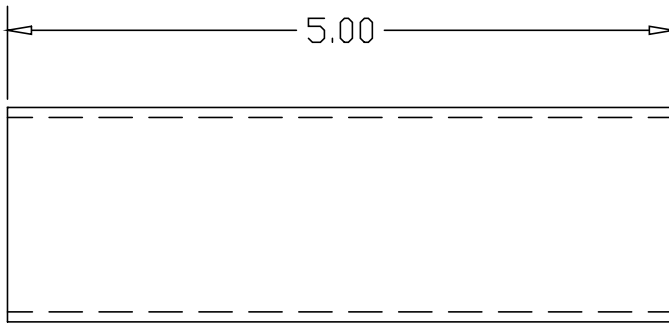
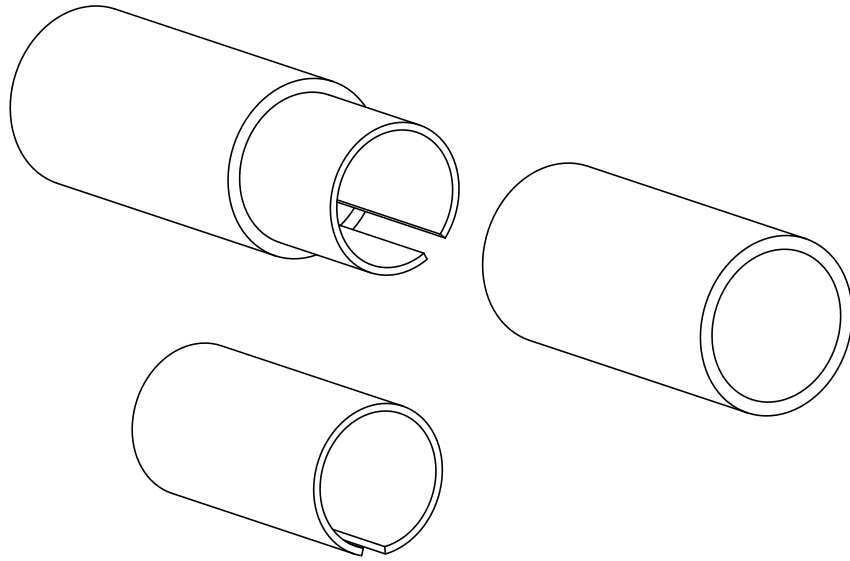

ALTERNATE MATERIAL	PART NUMBER
.080 (3003) ALUMINUM	1223
14 GA. (304) STAINLESS STEEL	1225

PART NAME 1-1/2" PIPE SIZE INSERT COUPLING				
MATERIAL 14 GA. HRP&O STEEL				
DATE 12/28/98		<b>THE WAGNER COMPANIES</b> R & B WAGNER, INC. AND J. G. BRAUN CO.		
DRAWN BY RJF				
FINISH MILL	SIZE A	WEIGHT .55 LBS	PART NUMBER 1222	REV