

REV
SH
1428
DWG NO

REVISIONS			
REV	DESCRIPTION	DATE	APPROVED

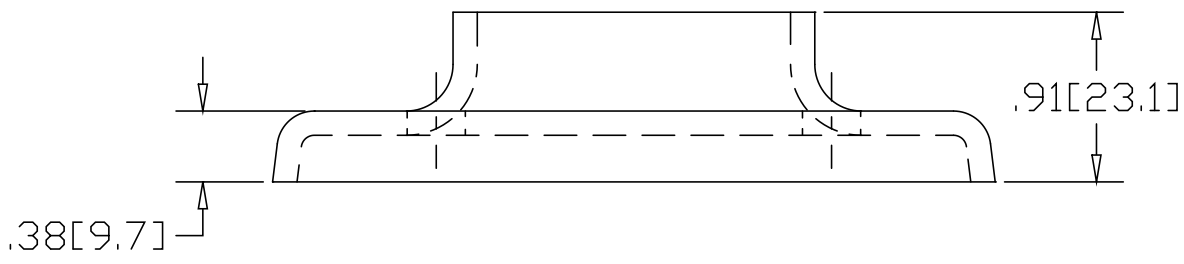
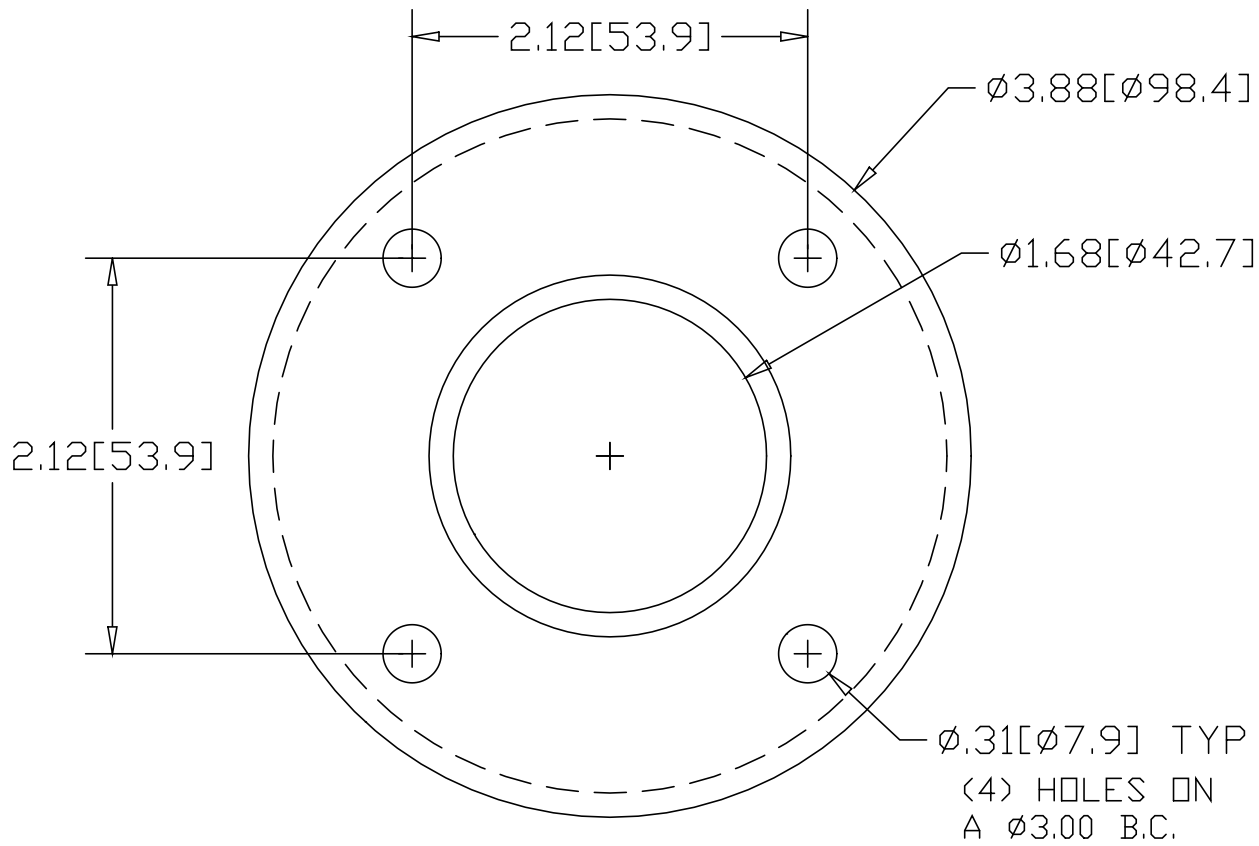

INCHES [MILLIMETERS]

*USE WITH ANCHOR PLATE
 #B1432 IN STEEL
 #PLB1432 ZINC PLATED STEEL
 #B1532 IN STAINLESS STEEL

ALTERNATE MATERIAL	PART NUMBER
.125 (3003) ALUMINUM ASTM B209	1468
10 GA. (304) STAINLESS STEEL ASTM A240	1528

PART NAME 1-1/4" PIPE HEAVY BASE FLANGE W/(4) HOLES			
MATERIAL 10 GA. HRP&D STEEL ASTM A569			
DATE 9/13/94		R & B WAGNER, INC.	
DRAWN BY RJF			
FINISH MILL		SIZE A	WEIGHT .50 LBS
			REV