

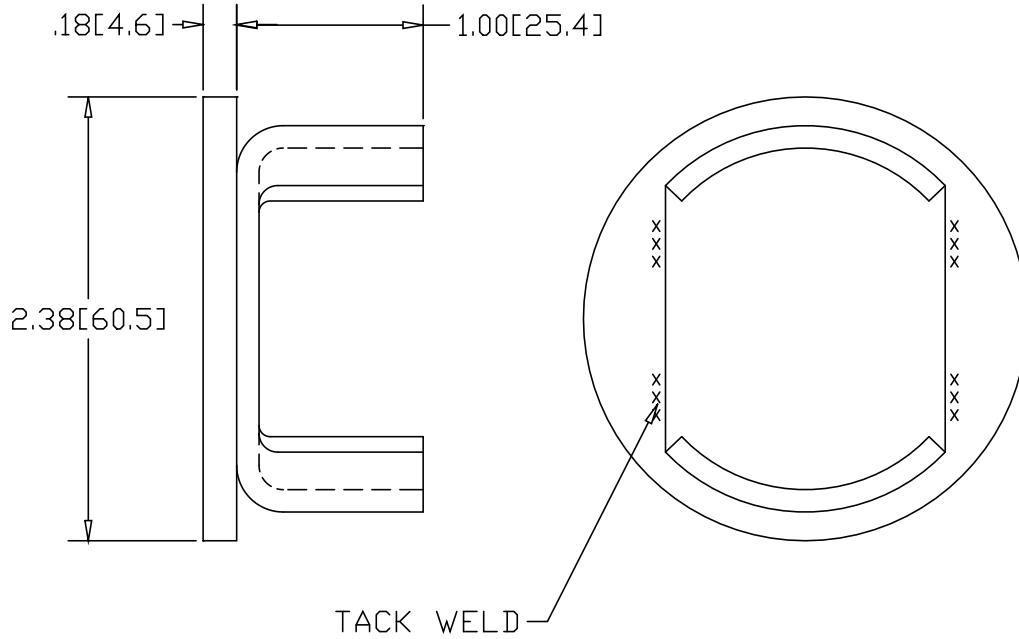

REV  
SH  
3288  
DWG NO

REVISIONS			
REV	DESCRIPTION	DATE	APPROVED



INCHES [MILLIMETERS]

ALTERNATE MATERIAL	PART NUMBER
.190 (3003) ALUMINUM ASTM B209	3293
7 GA 304 STAINLESS STEEL ASTM A240	3288-SS

PART NAME		2" PIPE SIZE TYPE-E DRIVE-ON DISK	
MATERIAL		7 GA. HRP&O STEEL ASTM A569	
DATE	10/11/96	 <b>THE WAGNER COMPANIES</b> R & B WAGNER, INC. AND J. G. BRAUN CO.	
DRAWN BY	RJF		
FINISH	MILL		
SIZE	WEIGHT	PART NUMBER	REV
A	.41 LBS	3288	