

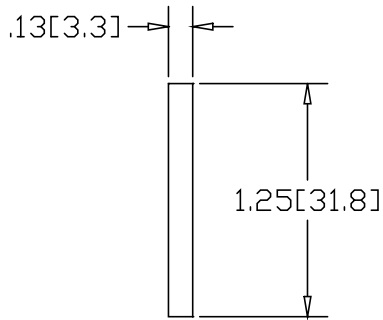

REV  
SH  
DWG NO  
D015

REVISIONS			
REV	DESCRIPTION	DATE	APPROVED

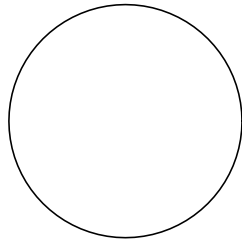
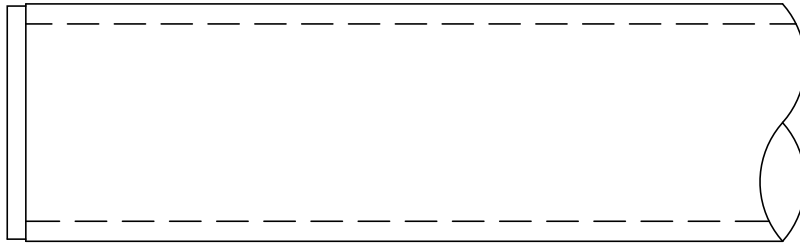
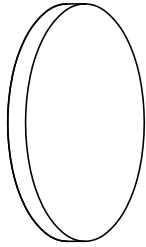

INCHES [MILLIMETERS]

ALTERNATE MATERIAL	PART NUMBER
.125 (3003) ALUMINUM ASTM B209	D016
10 GA. (304) STAINLESS STEEL ASTM A240	D017
.125 (260) BRASS ASTM B19,B36	D018

PART NAME				1.25" OD TUBE SIZE TYPE-D WELD-ON DISK			
MATERIAL				10 GA. HRP&D STEEL ASTM A569			
DATE		10/11/96		 <b>THE WAGNER COMPANIES</b> R & B WAGNER, INC. AND J. G. BRAUN CO.			
DRAWN BY		RJF					
FINISH		MILL					
SIZE	WEIGHT	PART NUMBER	REV				
A	.05 LBS	D015					