

REV
SH
4434
DWG NO

REVISIONS			
REV	DESCRIPTION	DATE	APPROVED

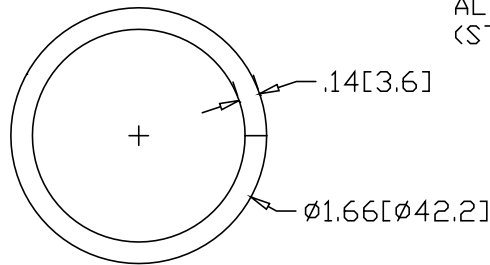
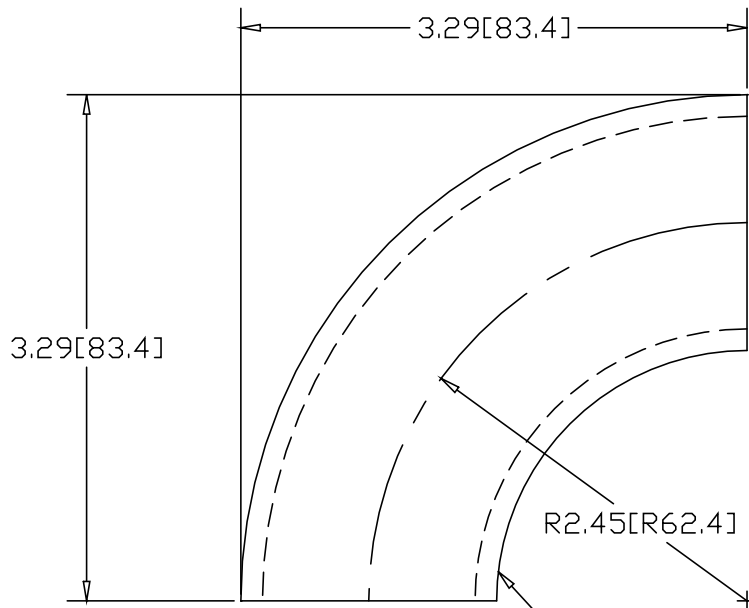

NOTE: UNWELDED SEAM
ALONG INSIDE RADIUS
(STEEL ELLS ONLY)

INCHES [MILLIMETERS]

ALTERNATE MATERIAL	PART NUMBER
1-1/4" SCH 40 (6063) ALUMINUM PIPE	4444

PART NAME		1-1/4" PIPE SIZE 90° ELL X 1-5/8" I.R.	
MATERIAL		10 GA. HRP&D STEEL ASTM A569	
DATE	8/18/95	 R & B WAGNER, INC.	
DRAWN BY	RJF		
FINISH	MILL	SIZE	A
		WEIGHT	.76 LBS
		PART NUMBER	4434
		REV	