

REV
SH
8045
DWG NO

REVISIONS			
REV	DESCRIPTION	DATE	APPROVED

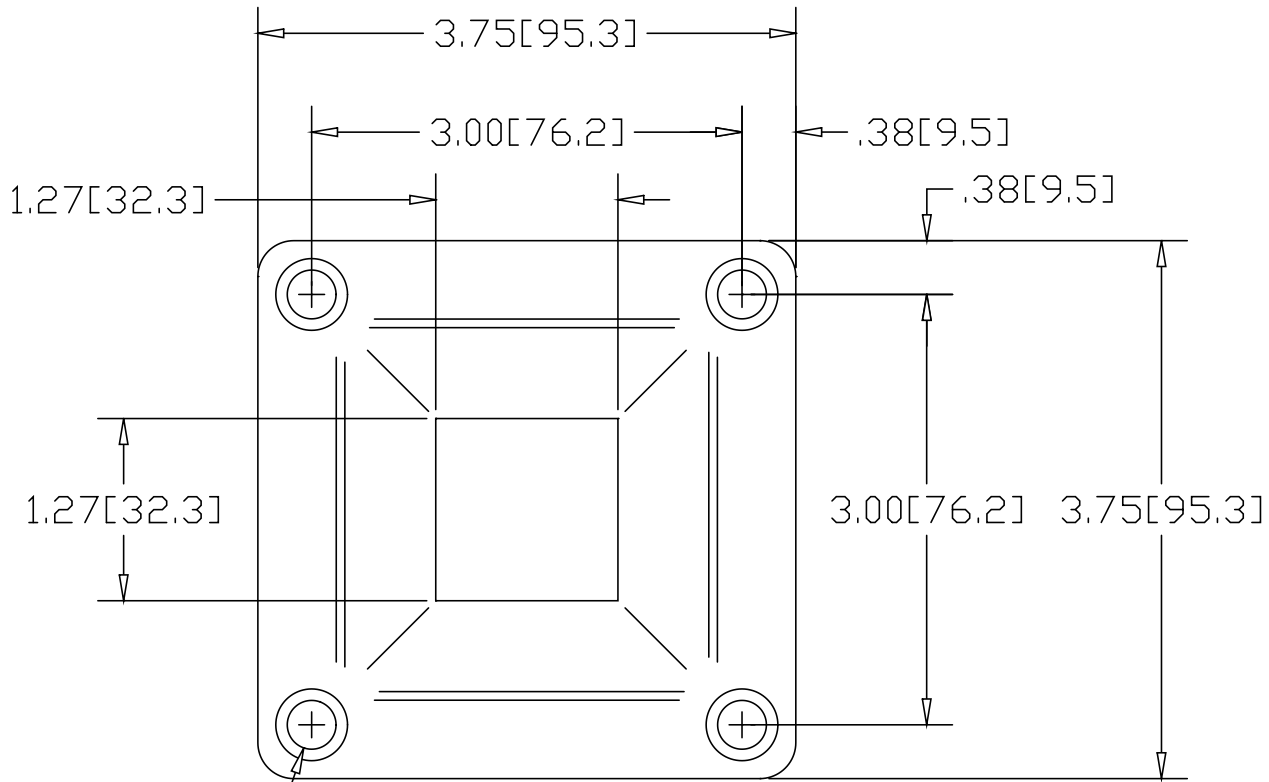

Ø.34[Ø8.6] TYP
W/C'SINK

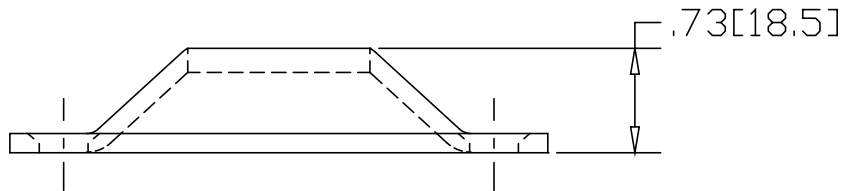

*USE WITH ANCHOR PLATE
#8057 IN STEEL
#8058 IN ALUMINUM

INCHES [MILLIMETERS]

ALTERNATE MATERIAL		PART NUMBER	
.125 (3003) ALUMINUM ASTM B209		8046	
PART NAME 1.25" SQUARE TUBE FLANGE WITH (4) HOLES			
MATERIAL 10 GA. HRP&D STEEL ASTM A569			
DATE	7/24/96	 R & B WAGNER, INC.	
DRAWN BY	RJF		
FINISH	MILL	SIZE	WEIGHT
		A	.50 LBS
		PART NUMBER	REV
		8045	