

REVISIONS			
REV	DESCRIPTION	DATE	APPROVED
A	REVISED TO SCREW-ON SADDLE	04/28/08	RJF
B	BAR BEND WAS .625 DIA.	10/06/09	RJF
C	CHAMFER WAS .12 X 60	01/29/10	PWH

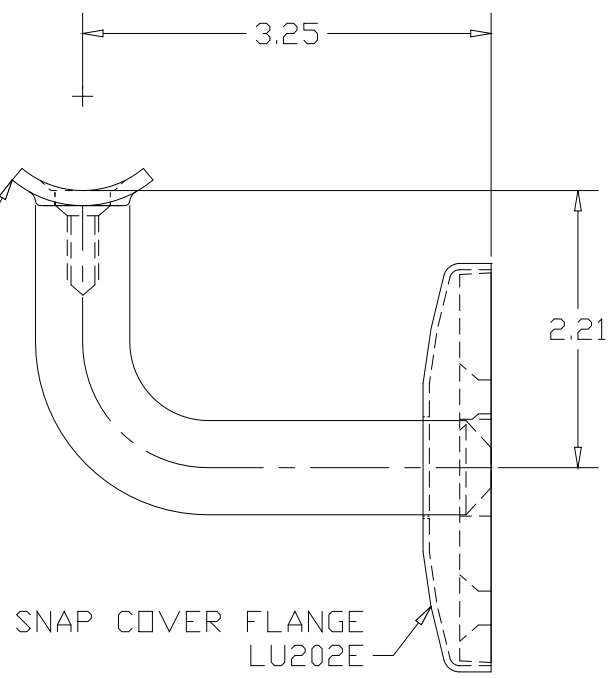
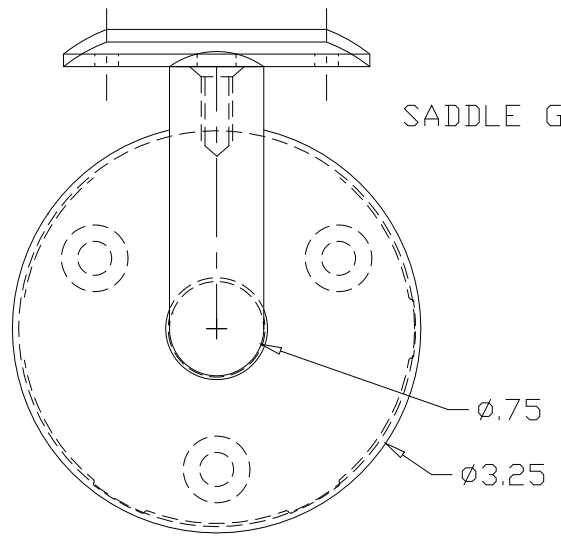
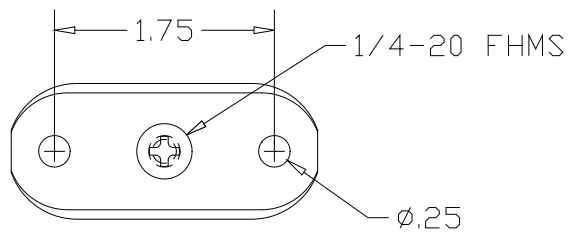

PART NAME		HANDRAIL BRACKET FOR UNLIT PIPE HANDRAIL		
MATERIAL		ALUMINUM		
DATE	02/27/07		THE WAGNER COMPANIES R & B WAGNER, INC. AND J. G. BRAUN CO.	
DRAWN BY	RJF			
FINISH	#4 SATIN	SIZE	WEIGHT	PART NUMBER
		A		LU207
				REV C