

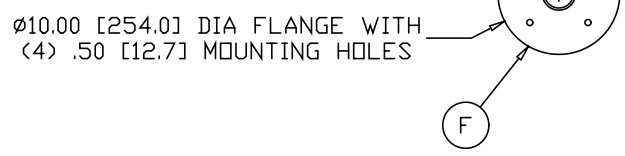

REVISIONS			
REV	DESCRIPTION	DATE	APPROVED
A	REVISED MTG LEGS TO SQUARE TUBE	04/24/01	RJF
B	REVISED TO MOUNTING FLANGE	01/30/03	RJF

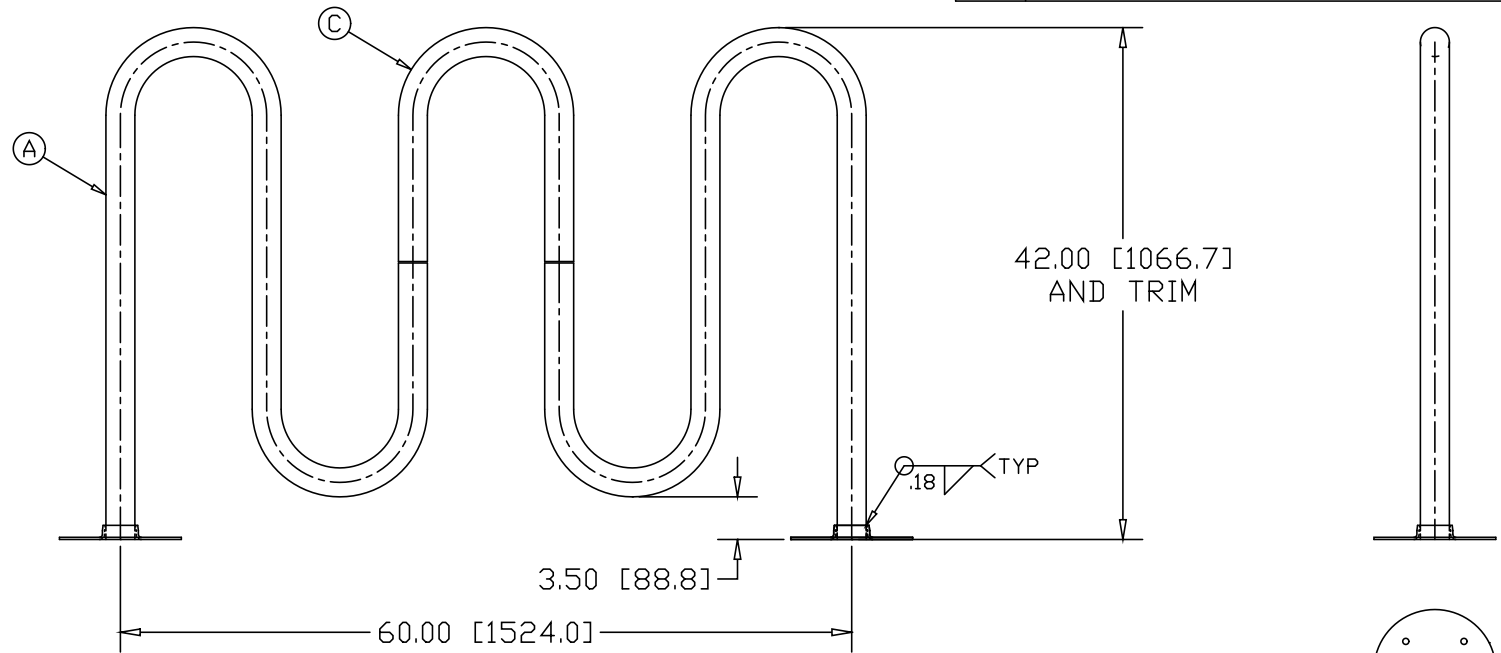

INCHES [MILLIMETERS]

ALTERNATE MATERIAL	PART NO.
2" SCH40 STEEL PIPE - GALVANIZED	SR5G-SM
2" STAINLESS STEEL PIPE SATIN FINISH	SR5SS-SM

PART NAME		5 LOOP BIKE RACK - SURFACE MOUNT		
MATERIAL		2" SCH 40 (2.38"O.D.) STEEL PIPE		
DATE	12/29/97	 <b>THE WAGNER COMPANIES</b> R & B WAGNER, INC. AND J. G. BRAUN CO.		
DRAWN BY	RJF			
FINISH	MILL	SIZE	WEIGHT	PART NUMBER
		A	87 lbs	SR5M-SM
				REV B