

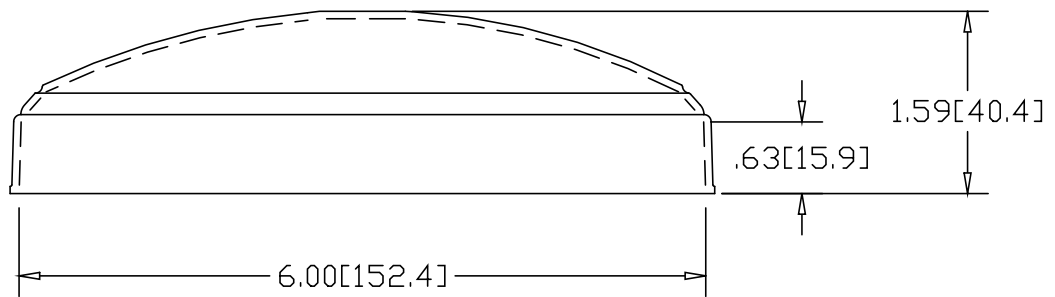

REV  
SH  
5149  
DWG NO

REVISIONS			
REV	DESCRIPTION	DATE	APPROVED

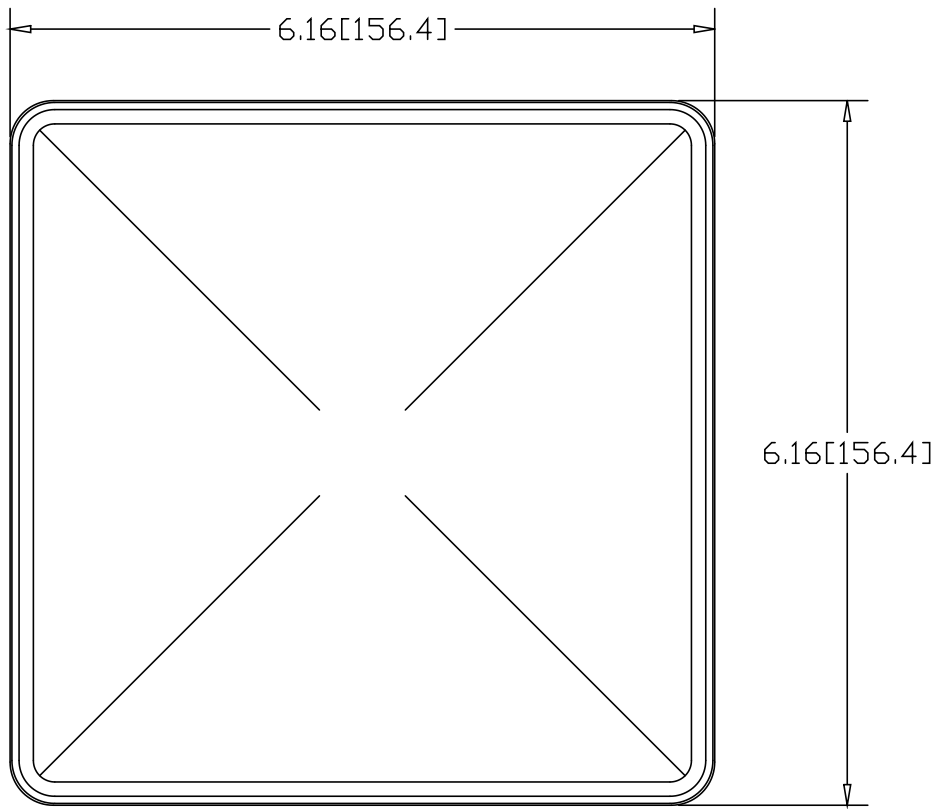

INCHES [MILLIMETERS]

ALTERNATE MATERIAL	PART NUMBER
.050 (3003) ALUMINUM ASTM B209	5149A

PART NAME		6.00" SQUARE NEWEL POST CAP					
MATERIAL		18 GA. STEEL ASTM A-366					
DATE	7/15/96	 <b>THE WAGNER COMPANIES</b> R & B WAGNER, INC. AND J. G. BRAUN CO.					
DRAWN BY	RJF						
FINISH	MILL						
SIZE	A	WEIGHT	.5 lbs	PART NUMBER	5149	REV	