

REV B
SH
DWG NO GR320F.4

REVISIONS			
REV	DESCRIPTION	DATE	APPROVED
A	REDRAWN	04/10/12	RJF
B	REVISED DIMENSIONS & TOLERANCES	02/28/13	RJF

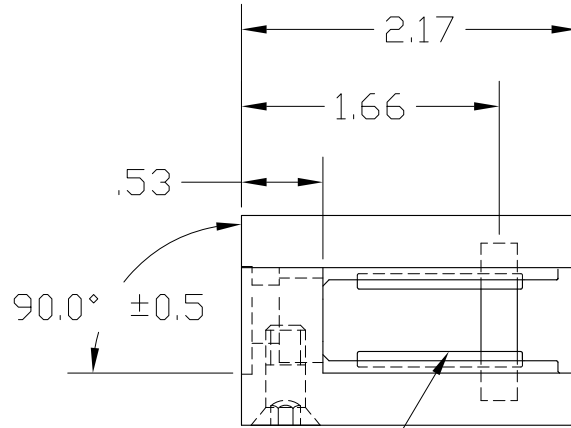

GASKETS INCLUDED FOR
.375 OR .500 PANEL

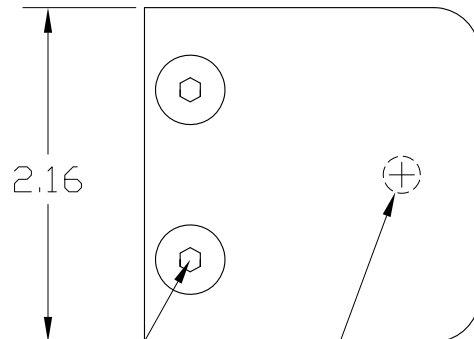
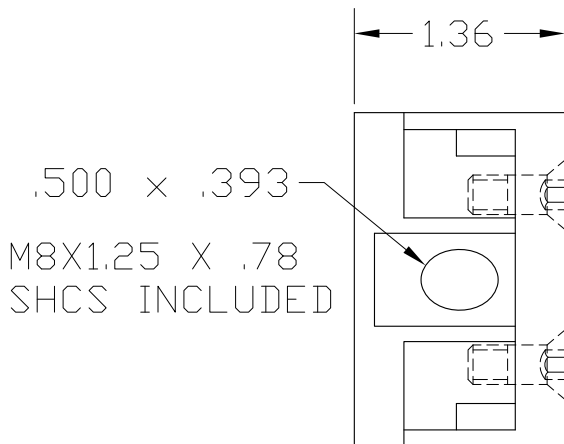

M6X1 X 16MM FHMS
(2) PLACES

Ø.240 GLASS PIN
OPTIONAL

NOTES:
1. BREAK ALL SHARP EDGES .015"

UNLESS OTHERWISE SPECIFIED
DIMENSIONS ON THIS DRAWING
ARE SUBJECT TO THE
FOLLOWING TOLERANCES:

X.X	= ±.100	ANGLES ±1°
X.XX	= ±.030	
X.XXX	= ±.010	

PART NAME		GLASS CLIP ASSEMBLY	
MATERIAL		TYPE 304 STAINLESS STEEL	
DATE	04/18/07		THE WAGNER COMPANIES R & B WAGNER, INC. AND J. G. BRAUN CO.
DRAWN BY	RJF		
FINISH	#4 SATIN	SIZE	WEIGHT
		A	1.04 LBS
		PART NUMBER	REV
		GR320F.4	B