

REV  
SH  
7908.120  
DWG NO

REVISIONS			
REV	DESCRIPTION	DATE	APPROVED

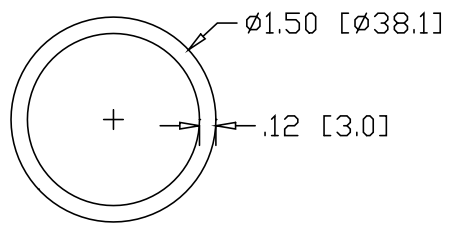
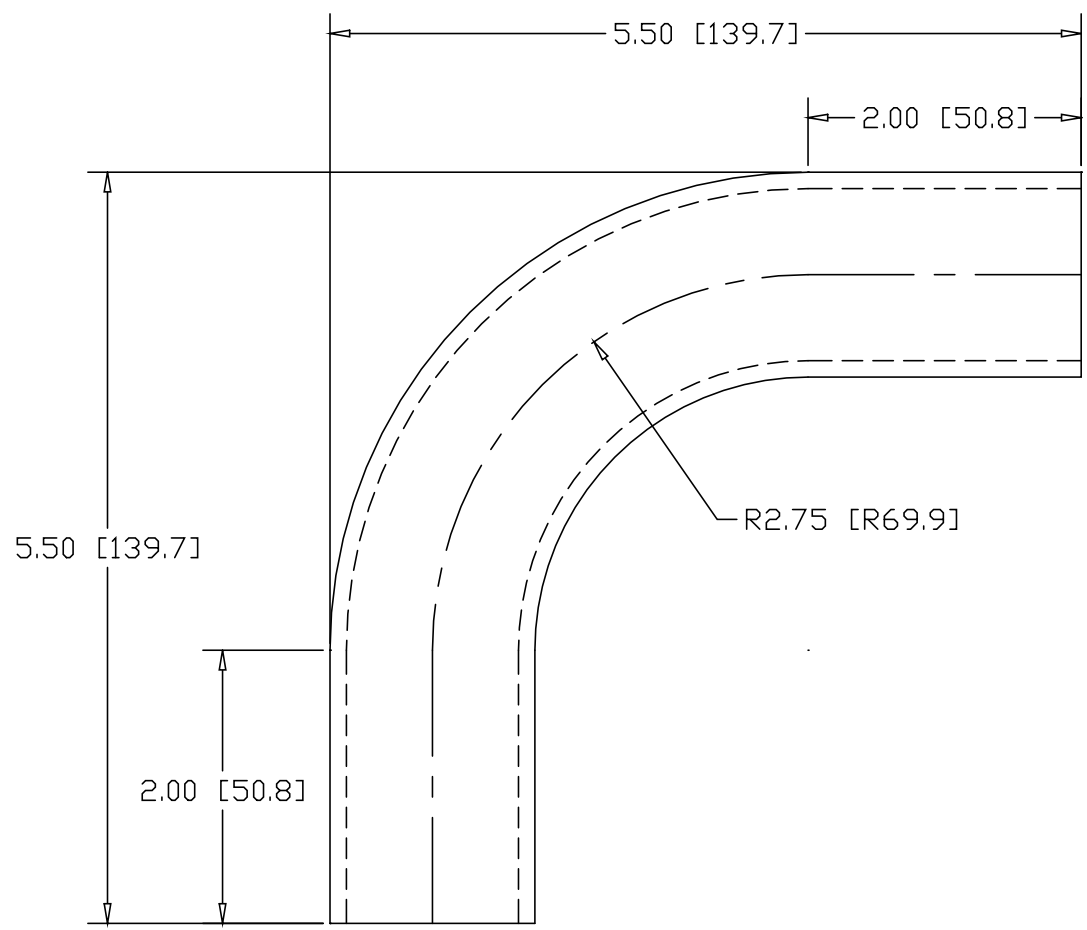

INCHES [MILLIMETERS]

ALTERNATE MATERIAL	PART NUMBER
1.50" O.D. X .125W (6061-T1) ALUMINUM TUBE	7924
1.50" O.D. X .120W (304) STAINLESS STEEL TUBE	7940.120

PART NAME 1.50" O.D. TUBE 90° ELL X 2.75" CLR W/(2) 2" TANGENTS			
MATERIAL 1.50" O.D. X .120W STEEL TUBE			
DATE 8/15/00	<b>WAGNER</b>	R & B WAGNER, INC.	
DRAWN BY RJF			
FINISH MILL			
SIZE A	WEIGHT 1.23 LBS	PART NUMBER 7908.120	REV