

REV  
SH  
DWG NO 4916T

REVISIONS			
REV	DESCRIPTION	DATE	APPROVED

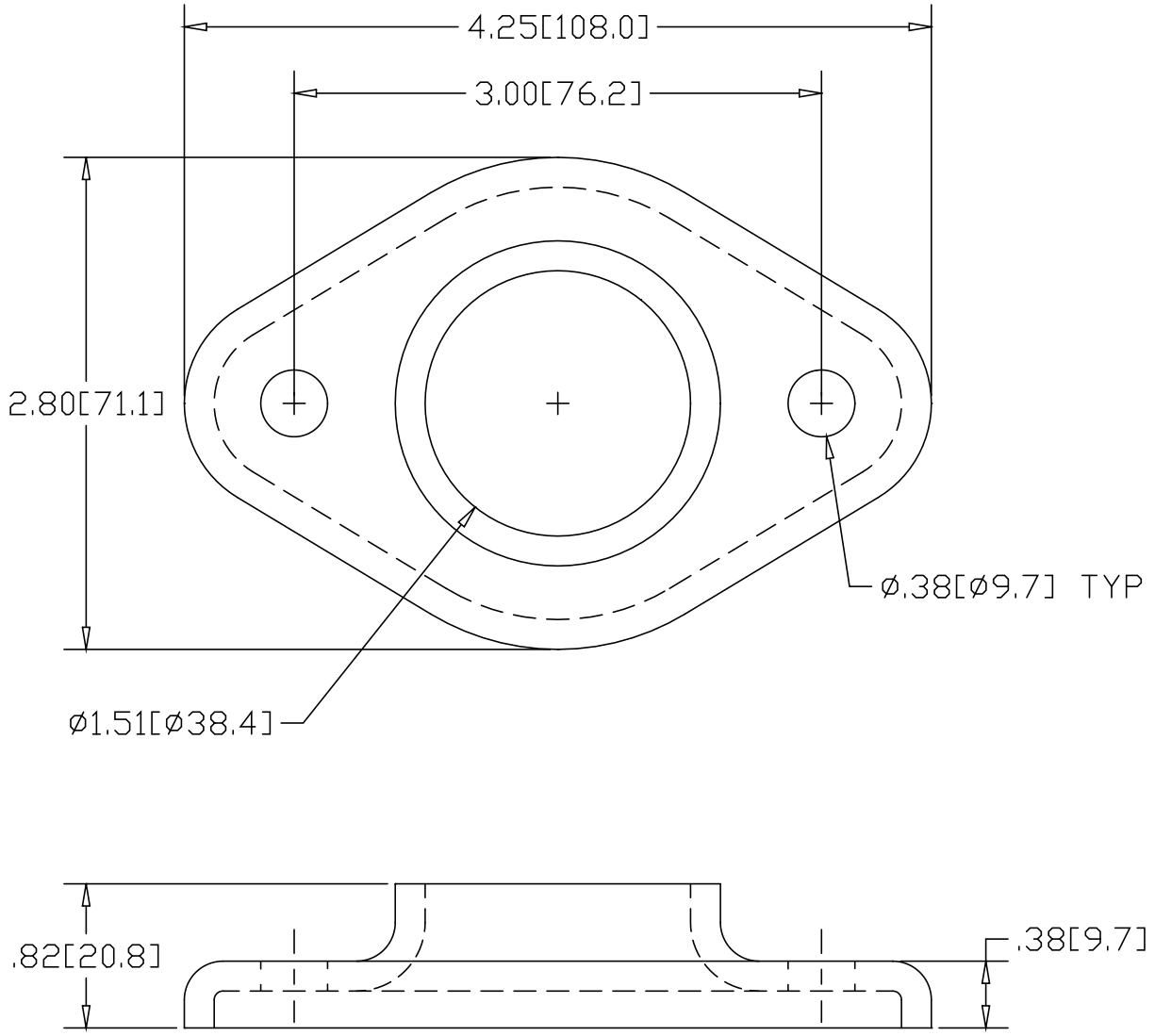

INCHES [MILLIMETERS]

\* USE WITH ANCHOR PLATE  
 #4914 IN STEEL  
 #4944 IN ALUMINUM  
 #4974 IN STAINLESS

ALTERNATE MATERIAL	PART NUMBER
.190 (3003) ALUMINUM ASTM B209	4946T
7 GA. (304) STAINLESS STEEL ASTM A240	4976T

PART NAME		1-1/2" O.D. TUBE TAPERED HEAVY BASE FLANGE W/(2) HOLES		
MATERIAL		7 GA. HRP&D STEEL ASTM A569		
DATE	5/22/95	 <b>R &amp; B WAGNER, INC.</b>		
DRAWN BY	RJF			
FINISH	MILL	SIZE	WEIGHT	PART NUMBER
		A	.41 LBS	4916T
				REV