

PARTS LIST

ITEM	QTY	PART NUMBER	DESCRIPTION
1	1	LG35242ESMA	End Post, Stainless Steel, 2.00 Inch x 0.50 Inch, 42 High, Brushed Satin Finish, Grade 316, Surface Mount, Post Assembly
2	2	LXTB51-1	Point Fitting, Stainless Steel, 51 mm Head, 1 Point, Tubular Body, Brushed Satin Finish, Grade 316, 0.50 Inch Glass
3	2	FAH3NM08C-0045	Screw, Stainless Steel, M8-1.25 x 45mm, Socket Flat Head Machine Screw, A4-70
5	1	FAH3N2520-0100	SCREW ST 1/4-20 X 1.00, FLAT ALLEN HEAD, STAINLESS STEEL
6	1	LG3SSP	Saddle Post stub,Stainless Steel, 1.5 x 0.5 O.D. x 0.12 Wall
7	1	LG325SMC	Flange, Stainless Steel, Snap-On Cover For2.00 Inch x 0.50 Inch, Satin Brushed Finish, Type 316
8	1	GB4382B.316	Bracket Saddle, SS, W/Countersunk Center Hole #4 Finish, TYPE 316

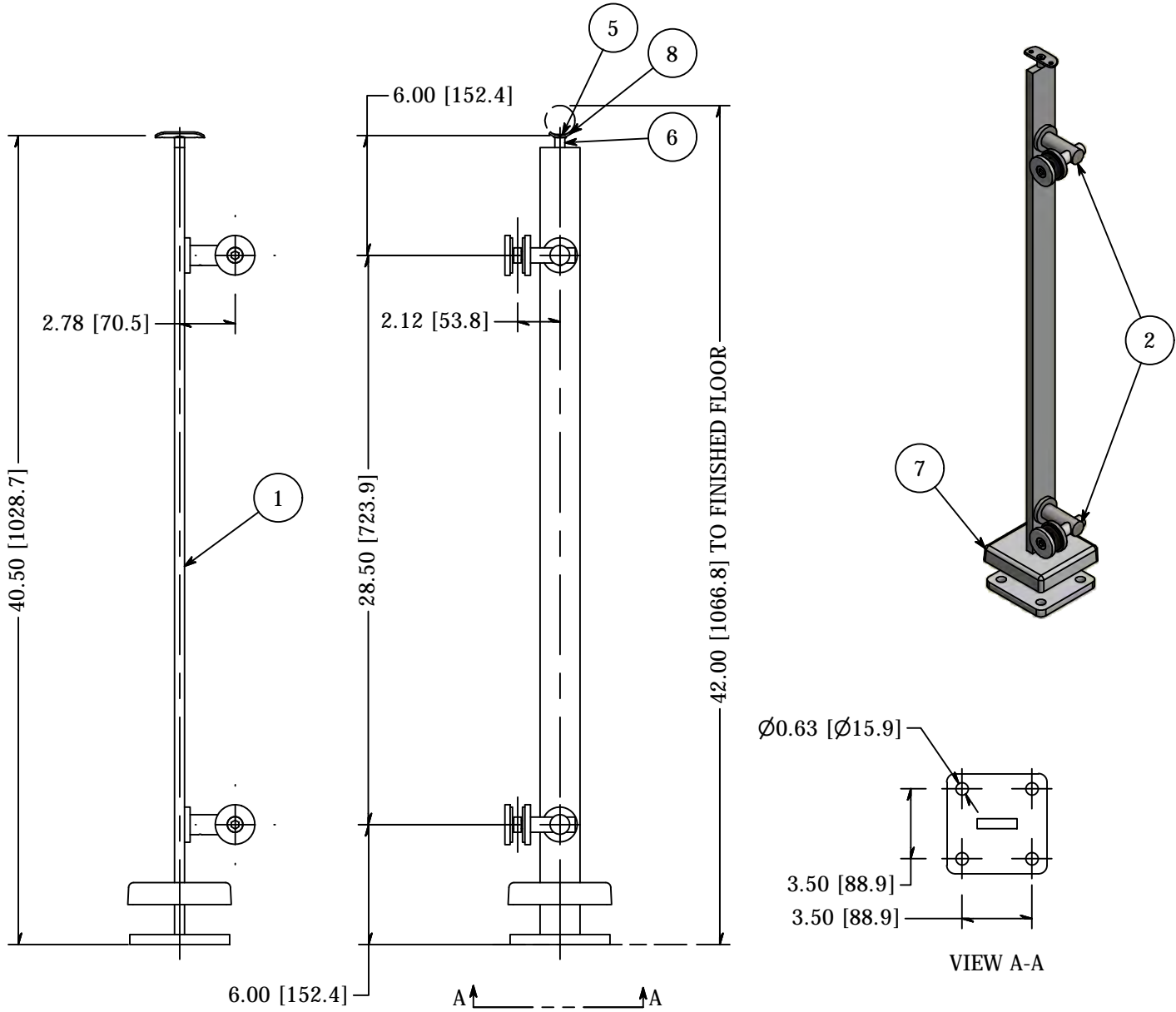

TOLERANCE UNLESS OTHERWISE NOTED, TOLERANCES TO CONFORM TO ES.03.011	CUT LENGTH:	FINISH: Satin Brushed	DESCRIPTION: End Post, Stainless Steel, 2.00 Inch x 0.50 Inch, 42 High, Brushed Satin Finish, Grade 316, Surface Mount, 2-Point Fitting	
	DEVELOPED LENGTH:	WEIGHT: N/A	MATERIAL:	MATERIAL DESC:
	TOOL NUMBER:		DATE: 9/13/2019	REV: -
			DRAWN BY: A. Seeboth	10600 W Brown Deer Rd Milwaukee, WI 53224 COLLABORATIVE METALWORKS http://www.wagnercompanies.com/
			PART NUMBER: LG35242CESM.4	