

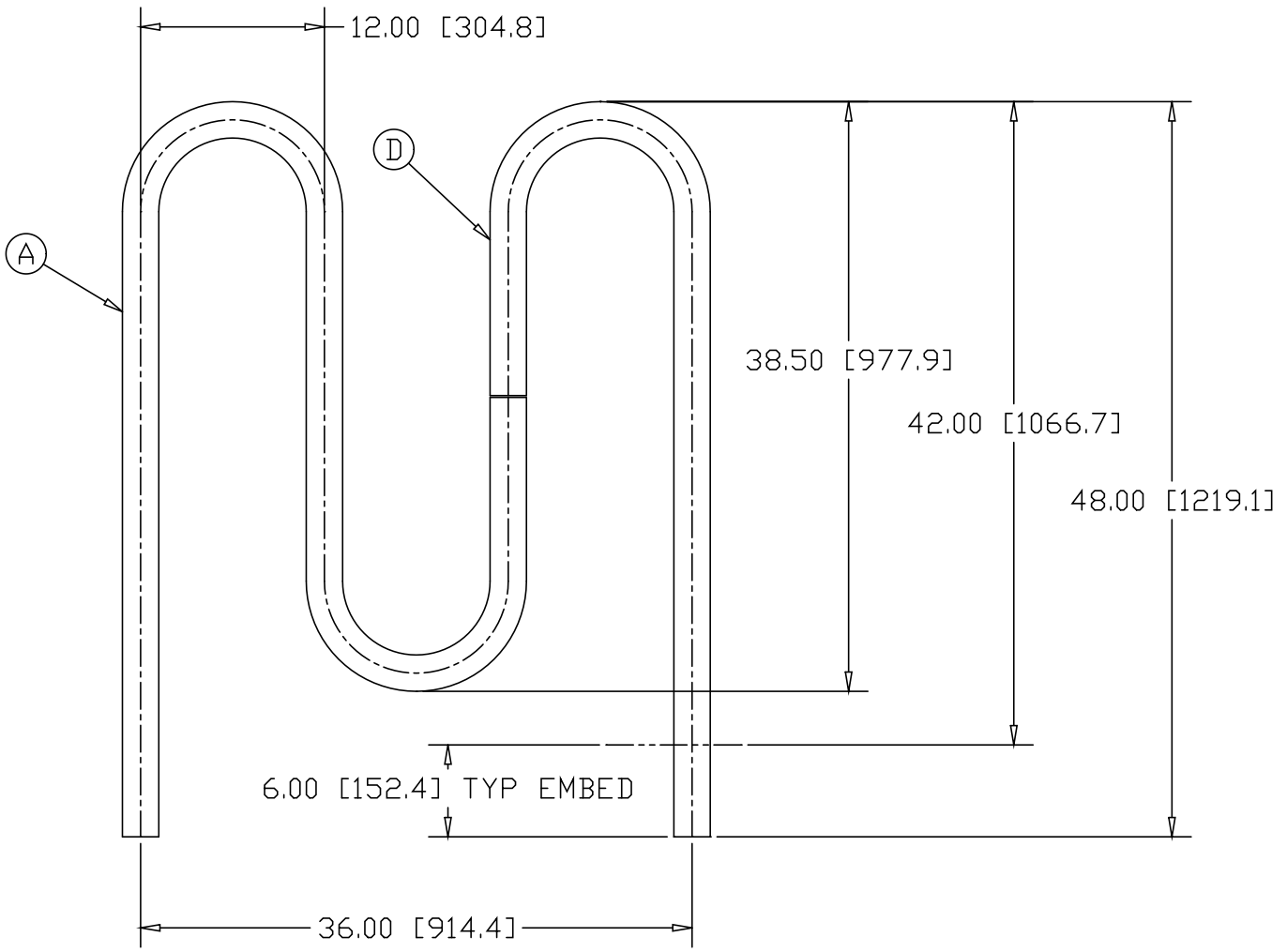

REV
A
SH
SR3M
DWG NO

REVISIONS			
REV	DESCRIPTION	DATE	APPROVED
A	EMBED WAS 10.00, 48.00 WAS 52.00	12/18/06	RJF



INCHES [MILLIMETERS]

ALTERNATE MATERIAL	PART NUMBER
2" SCH40 STEEL PIPE - GALVANIZED	SR3G
2" STAINLESS STEEL PIPE SATIN FINISH	SR3SS

PART NAME		3 LOOP BIKE RACK					
MATERIAL		2" SCH 40 (2.38" O.D.) STEEL PIPE					
DATE	12/29/97	 THE WAGNER COMPANIES R & B WAGNER, INC. AND J. G. BRAUN CO.					
DRAWN BY	RJF						
FINISH	MILL						
SIZE	A	WEIGHT	56.2 lbs	PART NUMBER	SR3M	REV	A