

REV
SH
9621
DWG NO

REVISIONS			
REV	DESCRIPTION	DATE	APPROVED

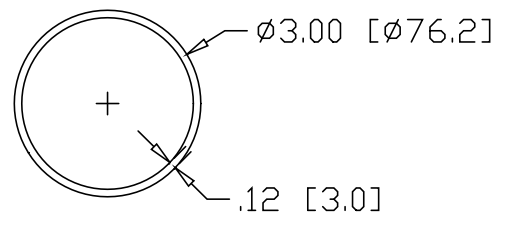
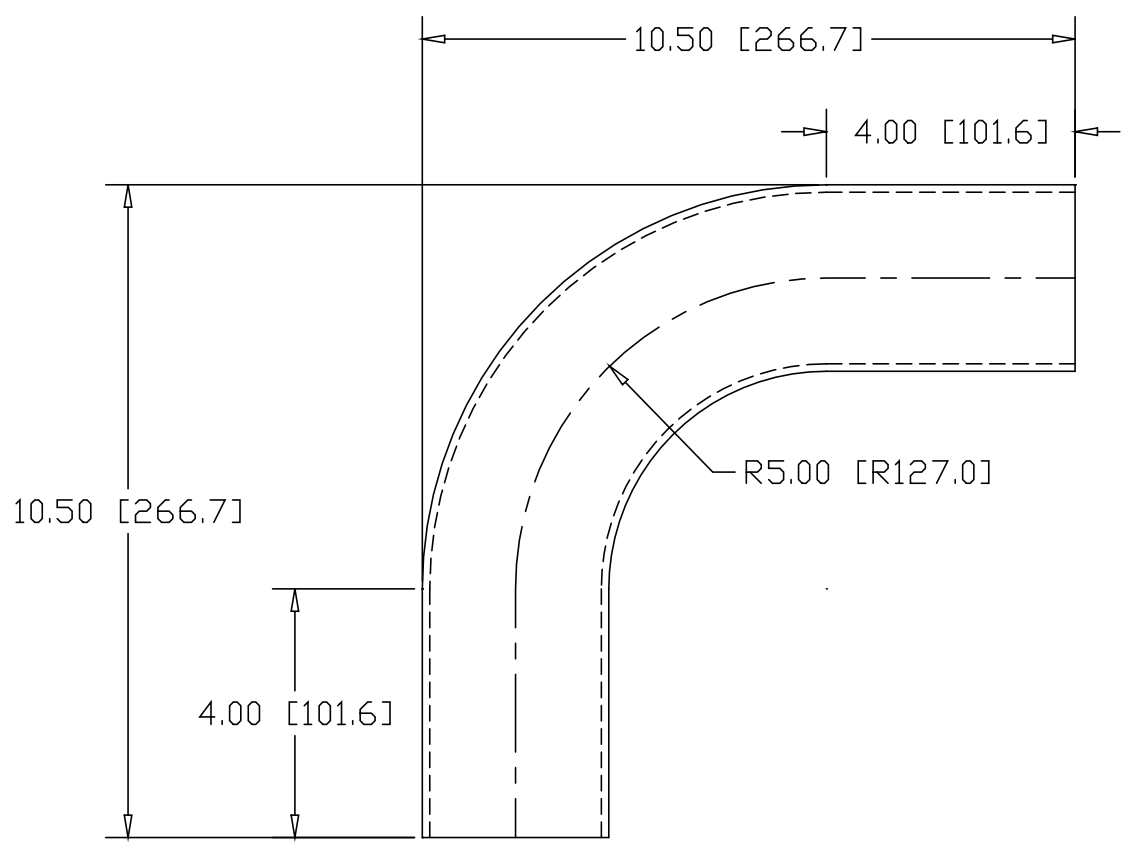

INCHES [MILLIMETERS]

ALTERNATE MATERIAL	PART NUMBER
3.00" OD X .125W 6061 ALUMINUM TUBE	9624
3.00" OD X .120W 304 STAINLESS STEEL TUBE	9626
3.00" OD X .125W 330 BRASS TUBE	9628

PART NAME 3.00" OD TUBE SIZE 90° ELL X 5" CLR W/⟨2⟩ 4" TANGENTS			
MATERIAL 3.00" OD X .120W STEEL TUBE			
DATE 9/2/03		THE WAGNER COMPANIES R & B WAGNER, INC. AND J. G. BRAUN CO.	
DRAWN BY RJF			
FINISH MILL			
SIZE A	WEIGHT 4.88 LBS	PART NUMBER 9621	REV