

REV  
SH  
4816  
DWG NO

REVISIONS			
REV	DESCRIPTION	DATE	APPROVED

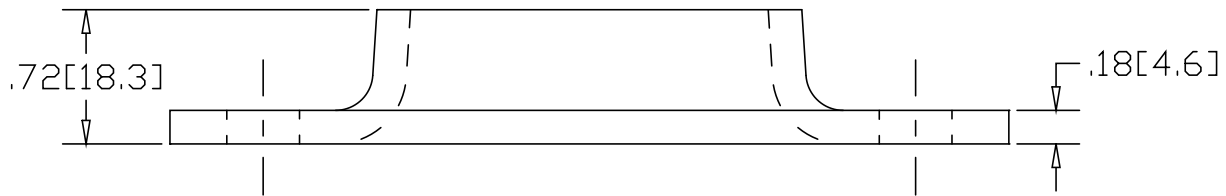
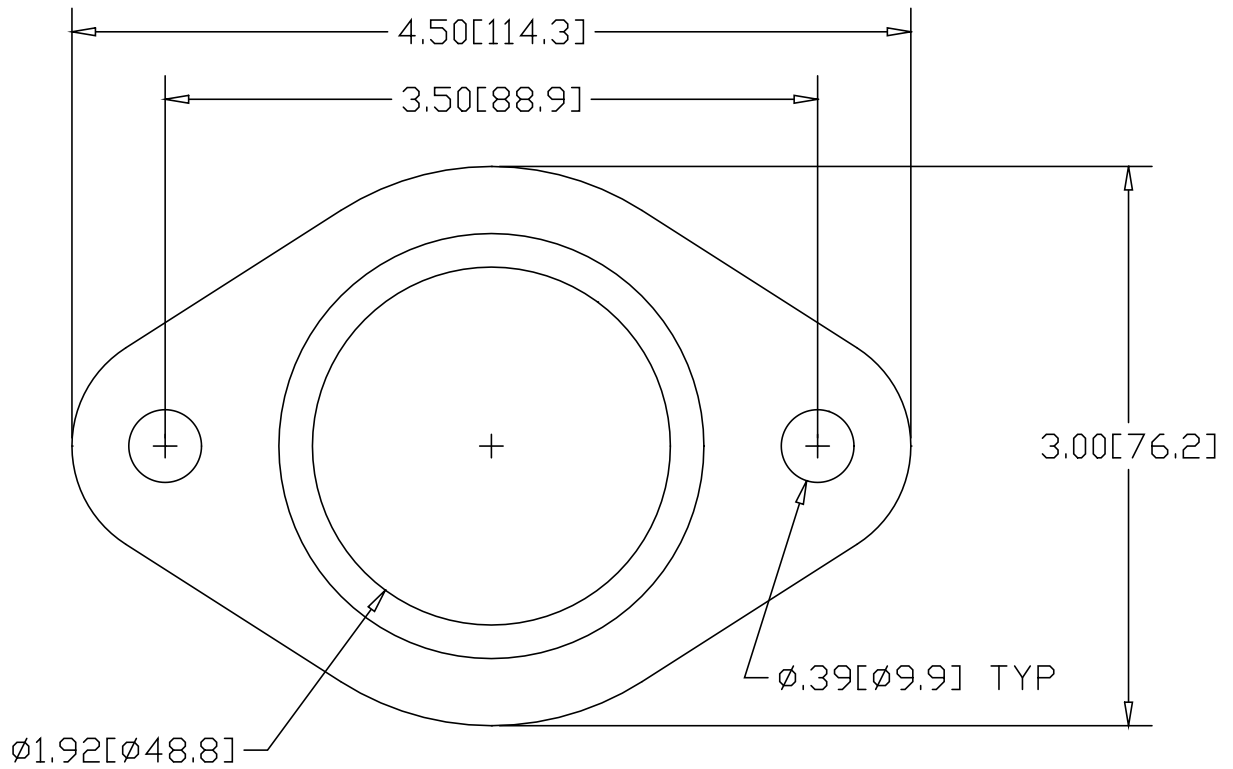

INCHES [MILLIMETERS]

ALTERNATE MATERIAL	PART NUMBER
.190 (3003) ALUMINUM ASTM B-209	4846
7 GA. (304) STAINLESS STEEL ASTM A-240	4876

PART NAME 1-1/2" PIPE SIZE TAPERED FLAT BASE FLANGE W/(2) HOLES				
MATERIAL 7 GA. HRP&D STEEL ASTM A-569				
DATE 5/1/95				
DRAWN BY RJF				
FINISH MILL				
SIZE A	WEIGHT .42 LBS	PART NUMBER 4816	REV	