

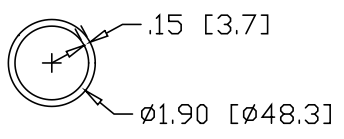

REV
SH
8313B
DWG NO

REVISIONS			
REV	DESCRIPTION	DATE	APPROVED

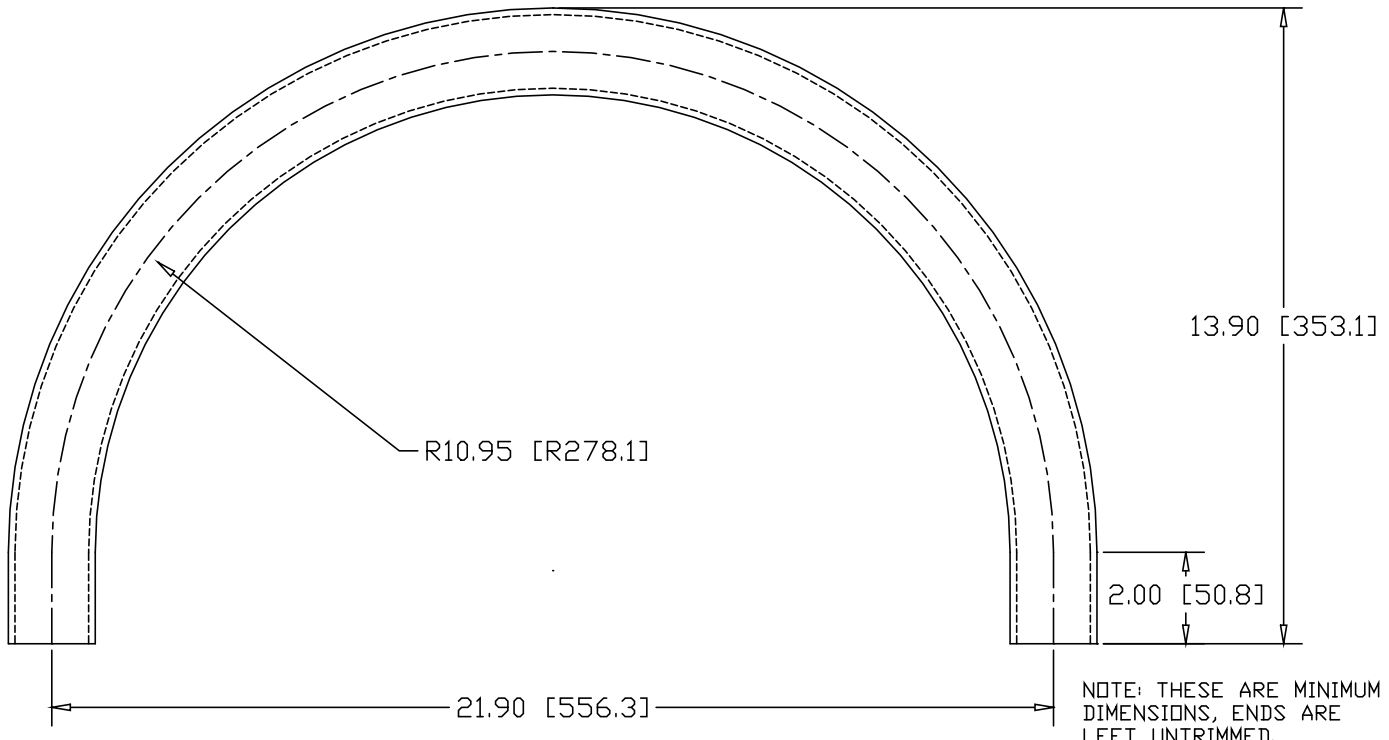

INCHES [MILLIMETERS]

ALTERNATE MATERIAL	PART NUMBER
1-1/2" SCH 40 (6063) ALUMINUM PIPE	8327B
1-1/2" SCH 40 (304) STAINLESS STEEL PIPE	8341B

PART NAME 1-1/2" PIPE SIZE 180° ELL X 10" I.R. W/ (2) 2" TANGENTS			
MATERIAL 1-1/2" SCH 40 A53 STEEL PIPE			
DATE 8/7/01		R & B WAGNER, INC.	
DRAWN BY JAH		PART NUMBER	8313B
FINISH MILL		SIZE A	WEIGHT 8.70 LBS