

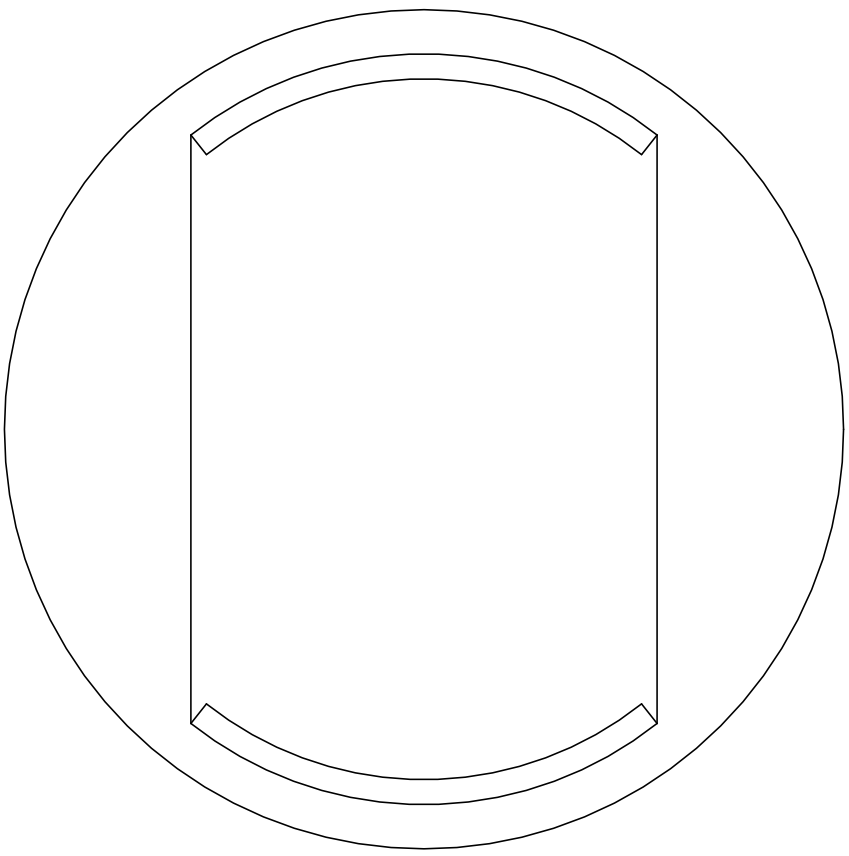

REV
SH
3288-4
DWG NO

REVISIONS			
REV	DESCRIPTION	DATE	APPROVED

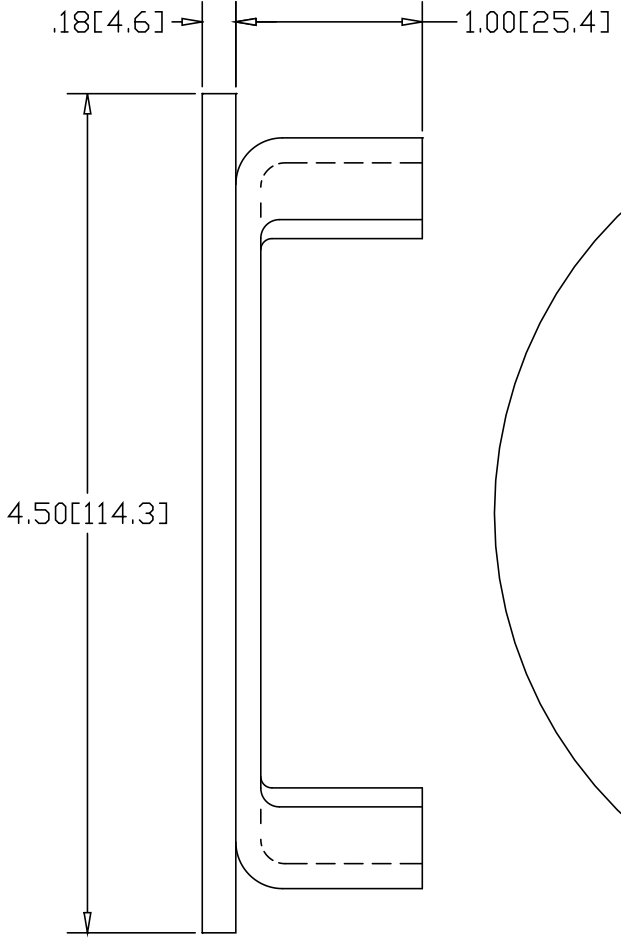

INCHES [MILLIMETERS]

ALTERNATE MATERIAL	PART NUMBER
.190 (3003) ALUMINUM ASTM B209	3293-4
7 GA 304 STAINLESS STEEL ASTM A240	3288-4-SS

PART NAME		4" PIPE SIZE TYPE-E DRIVE-ON DISK					
MATERIAL		7 GA. HRP&O STEEL ASTM A569					
DATE	10/11/96	 THE WAGNER COMPANIES R & B WAGNER, INC. AND J. G. BRAUN CO.					
DRAWN BY	RJF						
FINISH	MILL						
SIZE	A	WEIGHT	1.29 LBS	PART NUMBER	3288-4	REV	