

REV

SH

4811T

DWG NO

REVISIONS

REV	DESCRIPTION	DATE	APPROVED
-----	-------------	------	----------

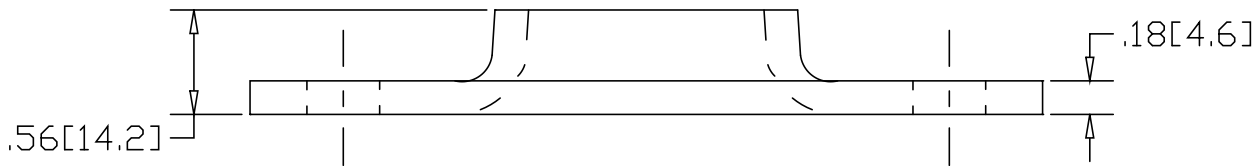
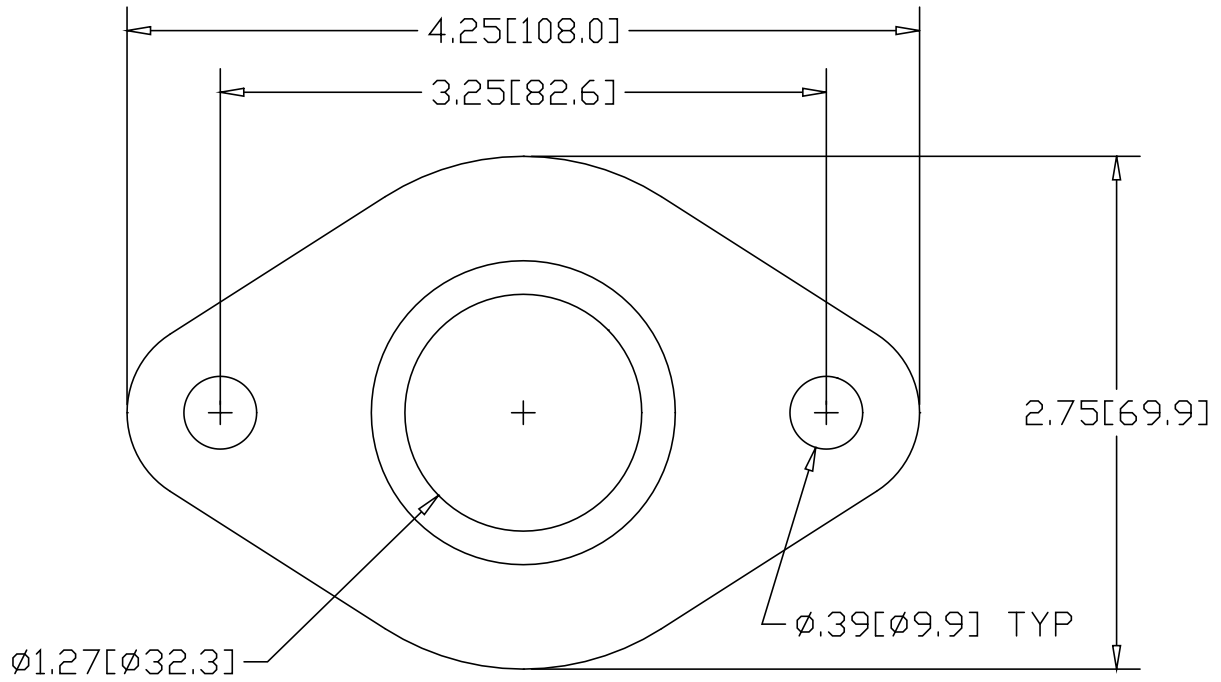

INCHES [MILLIMETERS]

ALTERNATE MATERIAL	PART NUMBER
.190 (3003) ALUMINUM ASTM B-209	4841T
7 GA. (304) STAINLESS STEEL ASTM A-240	4871T

PART NAME 1-1/4" O.D. TUBE TAPERED FLAT BASE FLANGE W/(2) HOLES			
MATERIAL 7 GA. HRP&O STEEL ASTM A-569			
DATE 5/9/95			
DRAWN BY RJF			
FINISH MILL			
SIZE A	WEIGHT .38 LBS	PART NUMBER 4811T	REV