

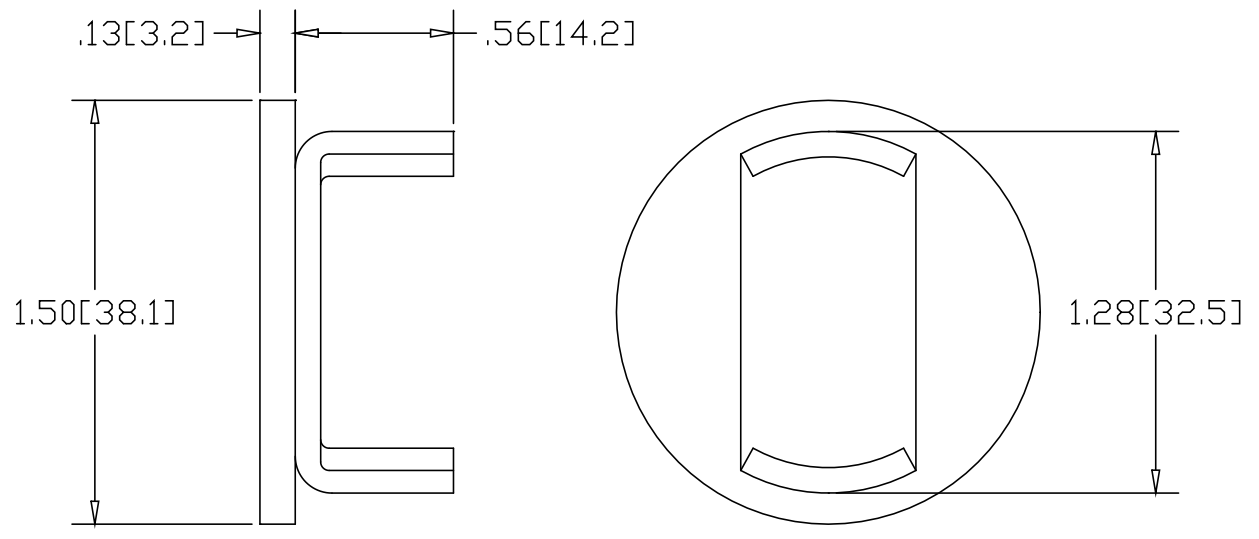

REV  
SH  
DWG NO D045E

REVISIONS			
REV	DESCRIPTION	DATE	APPROVED



INCHES [MILLIMETERS]

ALTERNATE MATERIAL	PART NUMBER
.125 (3003) ALUMINUM ASTM B209	D046E
10 GA. (304) STAINLESS STEEL ASTM A240	D041E

PART NAME 1-1/2" O.D. X .120W TUBE TYPE "E" DRIVE-ON DISK				
MATERIAL 10 GA. HRP&□ STEEL ASTM A569				
DATE 6/13/96	 <b>THE WAGNER COMPANIES</b> R & B WAGNER, INC. AND J. G. BRAUN CO.			
DRAWN BY RJF				
FINISH MILL		SIZE A	WEIGHT .12 LBS	PART NUMBER D045E