

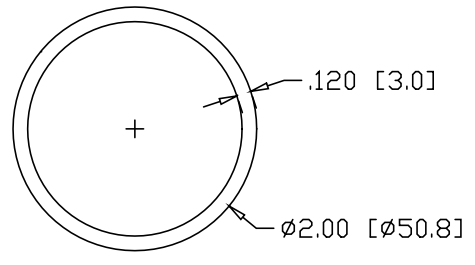

REV
SH
7958
DWG NO

REVISIONS			
REV	DESCRIPTION	DATE	APPROVED

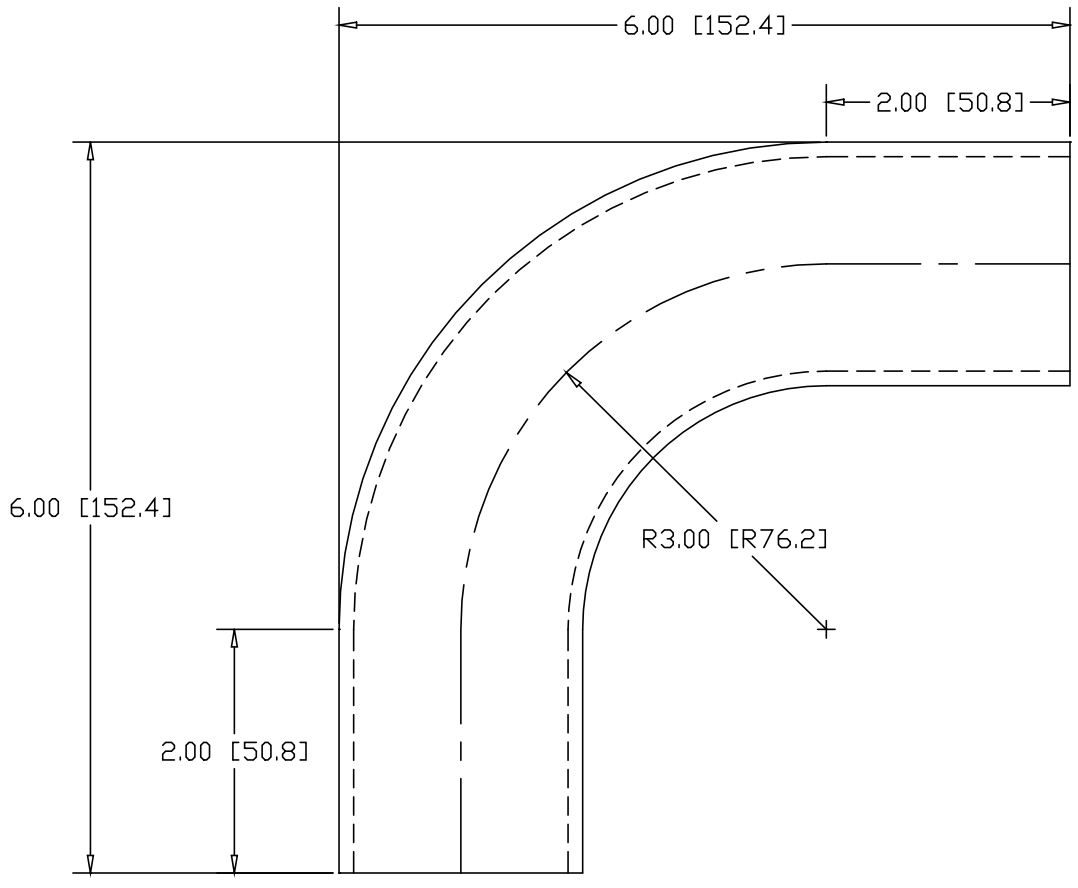

INCHES [MILLIMETERS]

ALTERNATE MATERIAL	PART NUMBER
2" Ø.D. X .125W (6061) ALUMINUM TUBE	7974
2" Ø.D. X .120W (304) STAINLESS STEEL TUBE	7990

PART NAME 2" Ø.D. TUBE 90° ELL X 3" CLR W/ (2) 2" TANGENTS			
MATERIAL 2" Ø.D. X .120W STEEL TUBE			
DATE 8/24/00		R & B WAGNER, INC.	
DRAWN BY RJF		SIZE A	WEIGHT 1.76 LBS
FINISH MILL			REV