

REVISIONS			
REV	DESCRIPTION	DATE	APPROVED
A	REVISED SADDLE	1/20/06	RDC

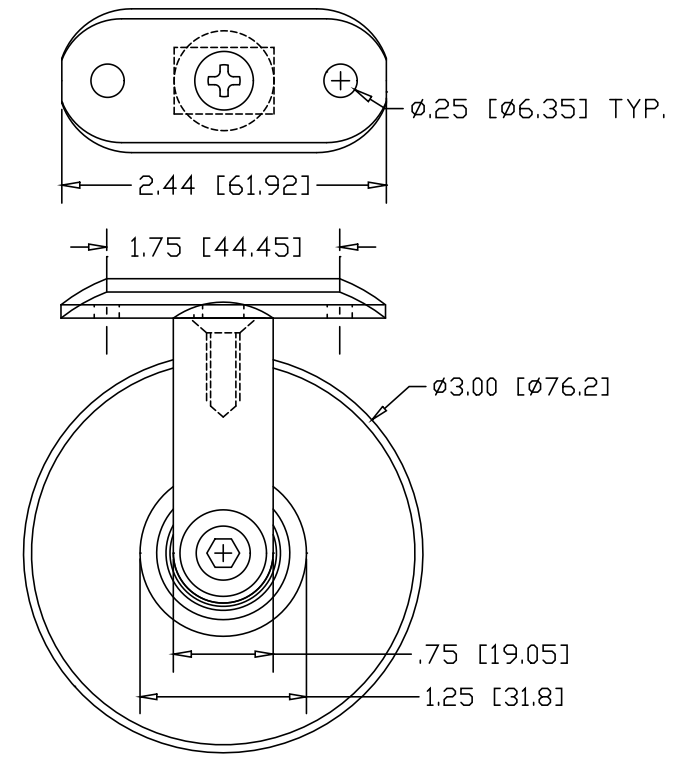

3/8-16 X 2" #6843
BUTTON HEAD BOLT

INCHES [MILLIMETERS]

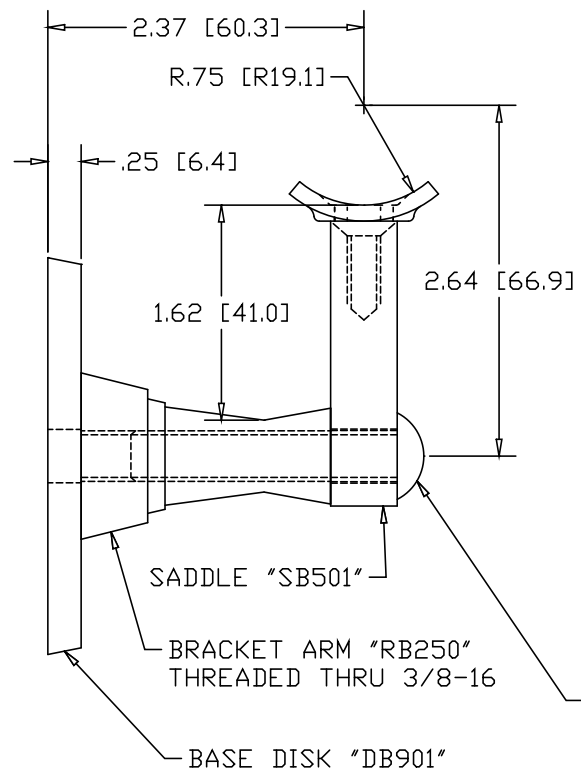
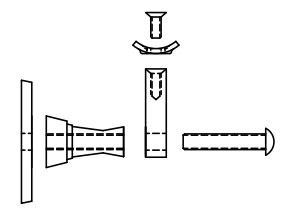

EXPLODED VIEW

PART NAME		MACHINED BRACKET, WALL MOUNT		
MATERIAL		BRASS		
DATE	9/15/03		THE WAGNER COMPANIES R & B WAGNER, INC. AND J. G. BRAUN CO.	
DRAWN BY	RJF			
FINISH	#6 SATIN	SIZE	WEIGHT	PART NUMBER
		A		MB4251W
				REV A