

REV
SH
1427AT
DWG NO

REVISIONS			
REV	DESCRIPTION	DATE	APPROVED

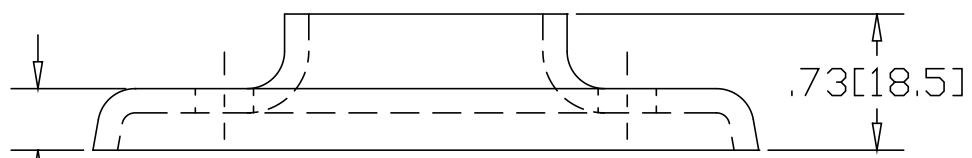
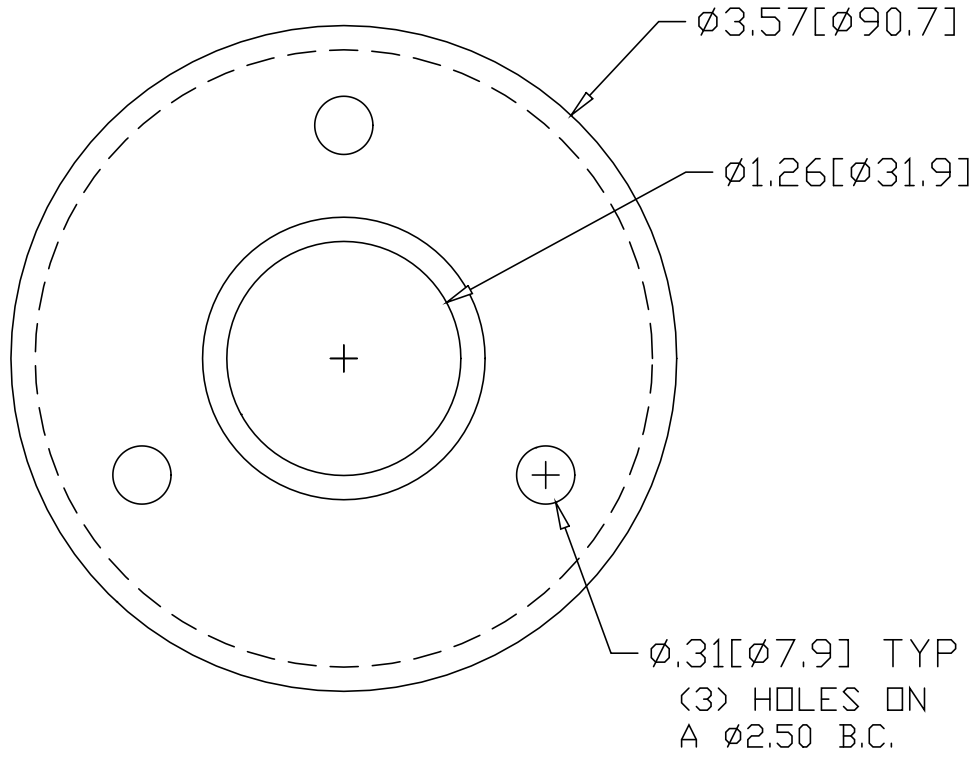

*USE WITH ANCHOR PLATE
#B1416 IN STEEL
#PLB1416 ZINC PLATED STEEL
#B1516 IN STAINLESS

INCHES [MILLIMETERS]

ALTERNATE MATERIAL		PART NUMBER					
.125 (3003) ALUMINUM ASTM B209		1467AT					
10 GA. (304) STAINLESS STEEL ASTM A240		1527AT					
PART NAME 1.25" OD TUBE HEAVY BASE FLANGE W/(3) HOLES							
MATERIAL 10 GA. HRP&D STEEL ASTM A569							
DATE	9/13/94						
DRAWN BY	RJF						
FINISH	MILL						
SIZE	A	WEIGHT	.41 LBS	PART NUMBER	1427AT	REV	