

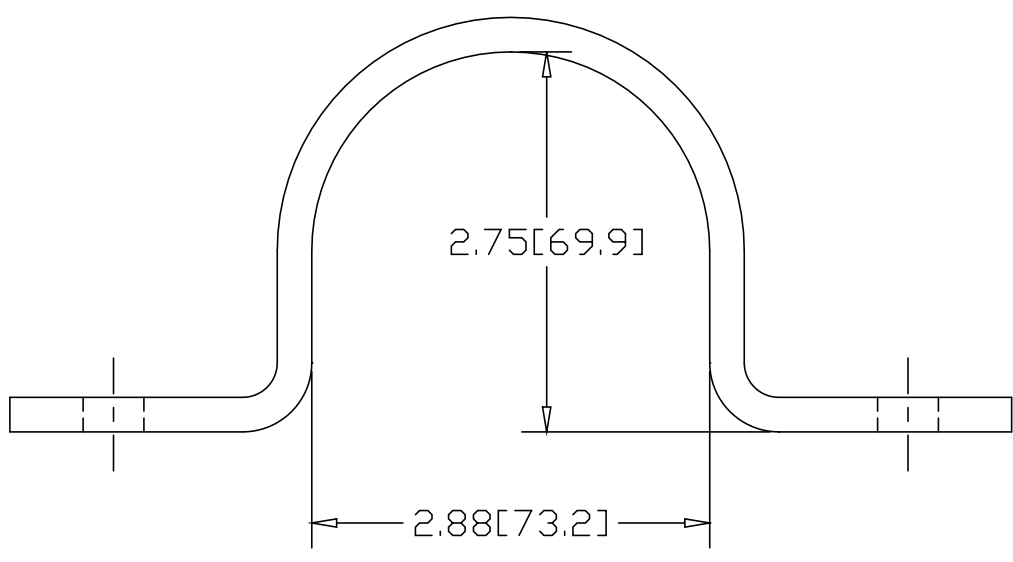

REV
SH
3755
DWG NO

REVISIONS			
REV	DESCRIPTION	DATE	APPROVED

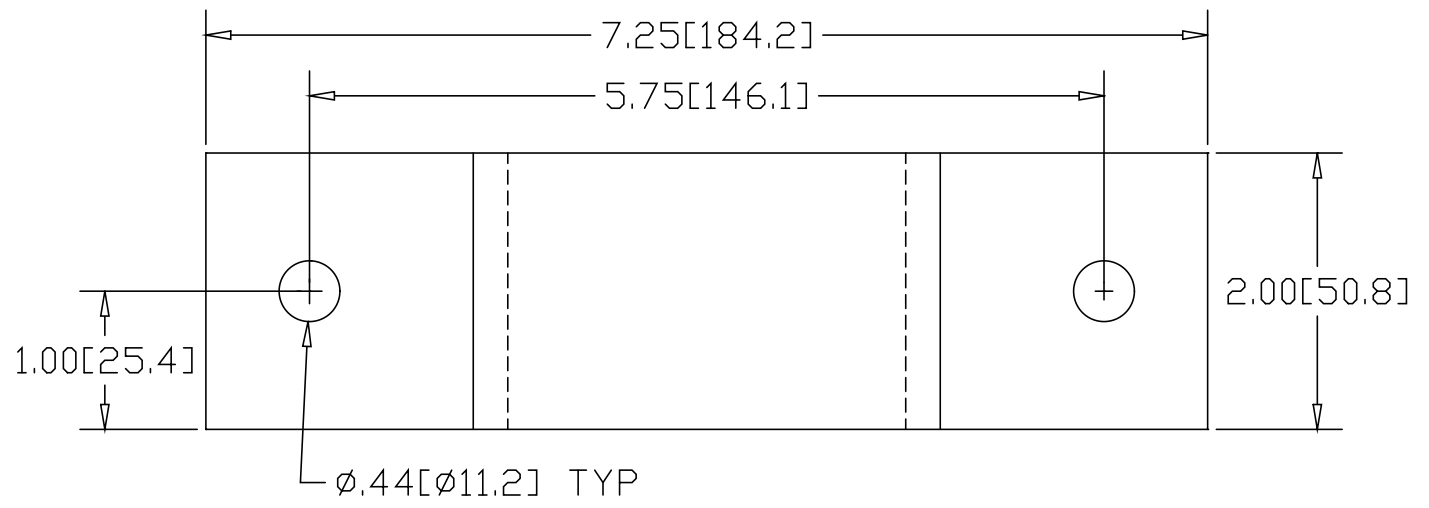

INCHES [MILLIMETERS]

ALTERNATE MATERIAL	PART NUMBER
.250 (3003) ALUMINUM ASTM B209	3755A
7 GA. (304) STAINLESS STEEL ASTM A240	3755-SS

PART NAME 2-1/2" PIPE (2.88" OD) X 2" WIDE U-BRACKET W/(2) HOLES				
MATERIAL .250 HRP&D STEEL ASTM A569				
DATE 1/13/00	 THE WAGNER COMPANIES R & B WAGNER, INC. AND J. G. BRAUN CO.			
DRAWN BY RJF		SIZE A	WEIGHT 1.40 LBS	PART NUMBER 3755
FINISH MILL				REV