

2



1

PARTS LIST

ITEM	QTY	PART NUMBER	DESCRIPTION
1	1	GR2LL5075HCB	Shoe Moulding, Aluminum, Level lock Plus, For .5 to .75 Glass, 2.75 Wide, 3.75 High, 20 Foot Lengths, Hole Counterbored, 12 in on Center, Mill Finish
2	2	LL5817	Level Lock Plus, Mechanism 10 Pack, for 5/8" Nominal Glass, .569-.726"
3	2	GR9LL1250	Shoe Isolator, Level Lock +, HDPE, 0.125 x 0.50 x 2.00, 10 pack

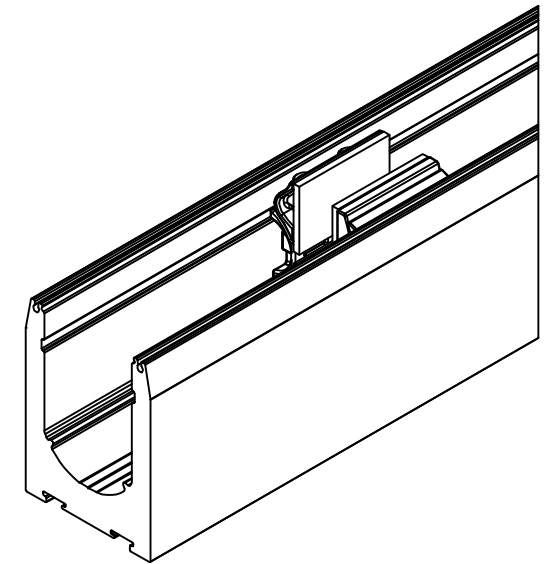
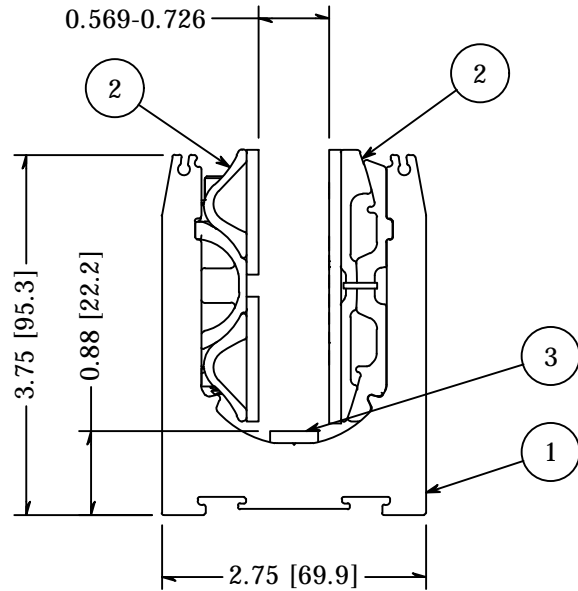

240.00 [6096.0]

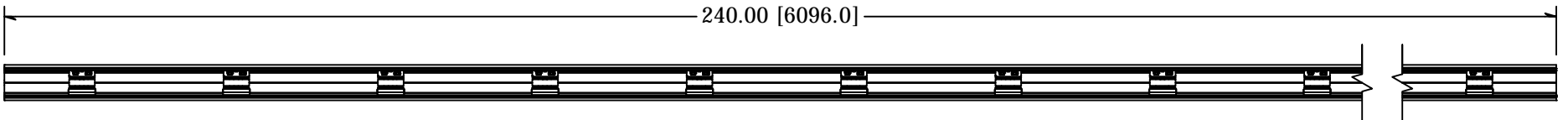

6.00 [152.4] TYP.

12.00 [304.8] TYP.

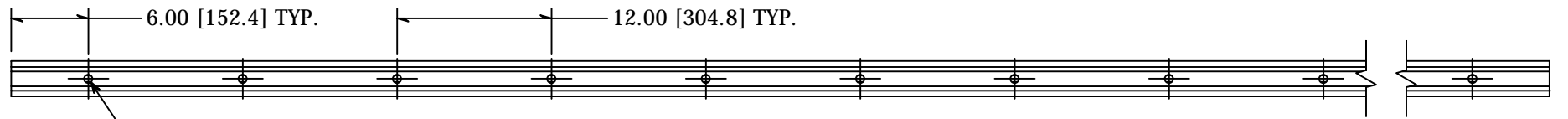
(20) Ø0.63 THRU
□ Ø1.13

TOLERANCE	CUT LENGTH:	FINISH:	DESCRIPTION:
X.XX +/- 0.01		MILL	Level Lock Plus, Sales kit, for 5/8", 15mm - 17mm glass, 20ft shoe HCB, W/ Mechanisms
X.XXX +/- 0.005	DEVELOPED LENGTH:	WEIGHT:	MATERIAL:
Angle +/- 0.5	20FT	N/A	MATERIAL DESC:
Unless Otherwise Specified	TOOL NUMBER:		DATE: 4/8/2021
			DRAWN BY: A. Seeboth
			REV: 1
			PART NUMBER: LL5817KIT20

WAGNER™
 COLLABORATIVE METALWORKS
 10600 W Brown Deer Rd
 Milwaukee, WI 53224
<http://www.wagnercompanies.com/>

2



1