

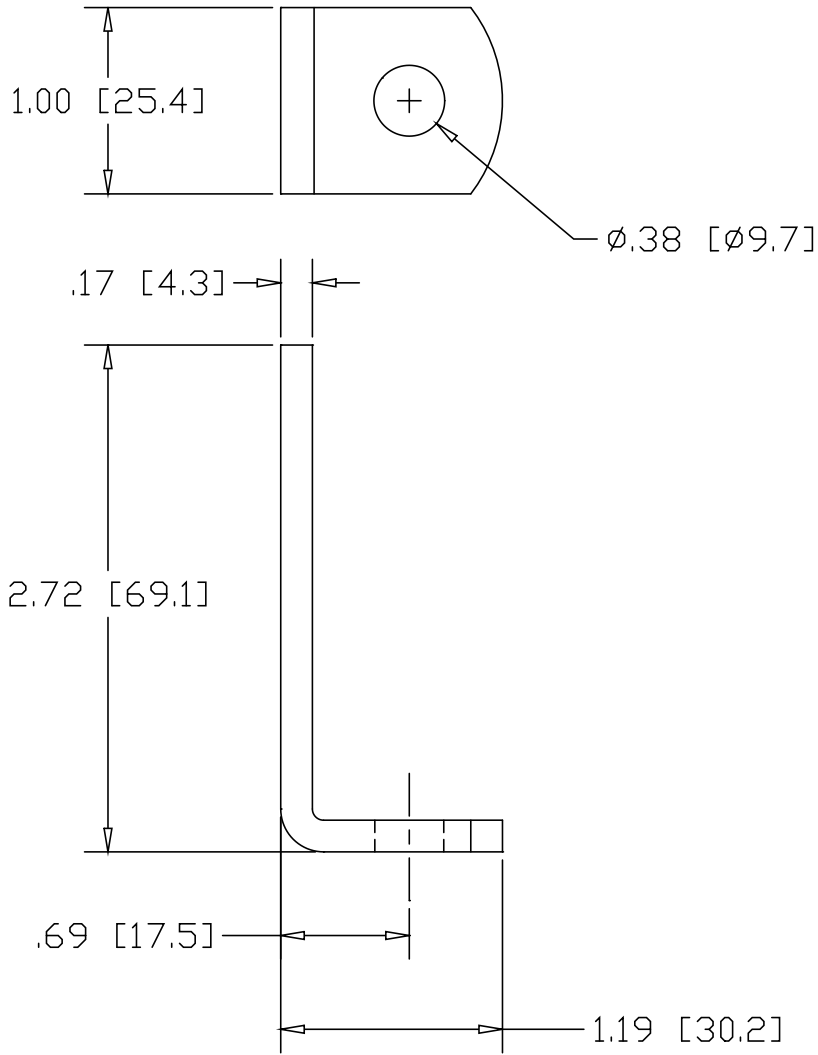

REV  
SH  
37  
DWG NO

REVISIONS			
REV	DESCRIPTION	DATE	APPROVED



INCHES [MILLIMETERS]

ALTERNATE MATERIAL	PART NUMBER
8 GA. HRP&D STEEL ASTM A569 ZINC PLATED	37P
.188 X 1.00 6063-T52 ALUMINUM BAR	38

PART NAME				WELD MOUNT BRACKET	
MATERIAL				8 GA. HRP&D STEEL ASTM A569	
DATE	8/15/03	 <b>THE WAGNER COMPANIES</b> R & B WAGNER, INC. AND J. G. BRAUN CO.			
DRAWN BY	RJF				
FINISH	MILL				
SIZE	A	WEIGHT	.171 LBS	PART NUMBER	37
				REV	

