

REVISIONS			
REV	DESCRIPTION	DATE	APPROVED

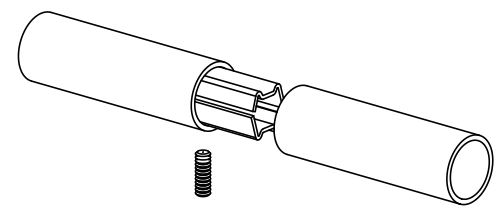

1-1/2" SCHEDULE 40 PIPE  
(1.90 O.D. X .145W)  
ALSO 2" O.D. X .120W TUBE

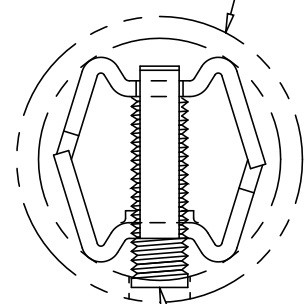
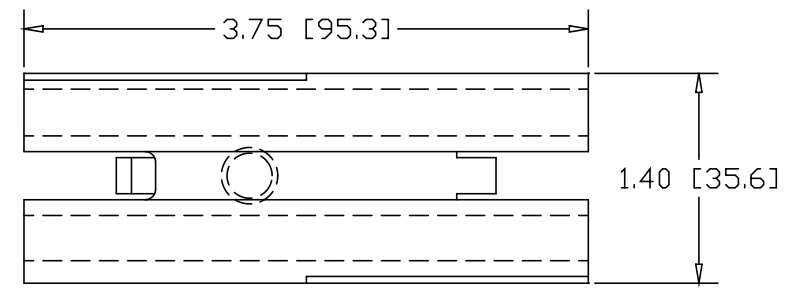

3/8-16  
SOCKET HEAD  
SET-SCREW

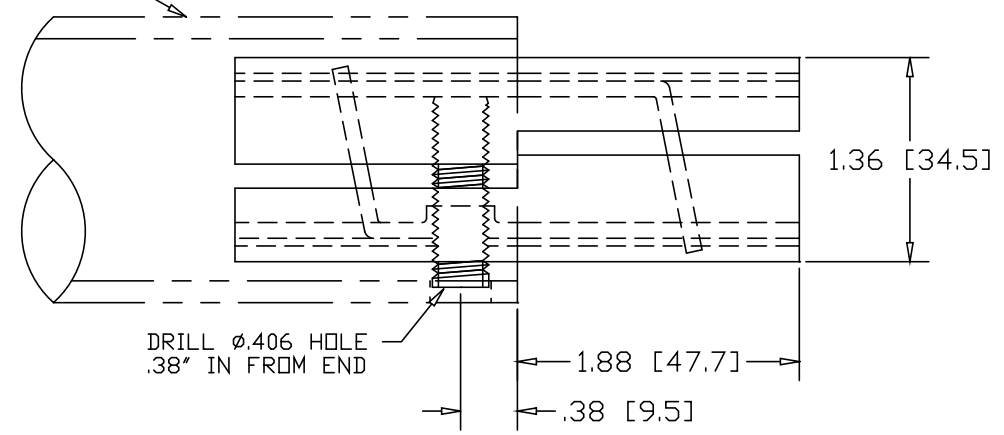

DRILL  $\phi$ .406 HOLE  
.38" IN FROM END

INCHES [MILLIMETERS]

ALTERNATE MATERIAL	PART NO.
12 GA. STEEL HOT DIP GALVANIZED	G3318
12 GA. STEEL ZINC PLATED	PL3318
.090 (3003) ALUMINUM ASTM B209	3319
.090 (304) STAINLESS STEEL ASTM A240	3321

PART NAME 1-1/2" SCH40 PIPE & 2.00" O.D. X 120W TUBE, SINGLE-LOCK SPLICE-LOCK				
MATERIAL 12 GAUGE HRP&D STEEL ASTM A569				
DATE 3/22/93	 <b>THE WAGNER COMPANIES</b> R & B WAGNER, INC. AND J. G. BRAUN CO.			
DRAWN BY RJF				
FINISH MILL	SIZE A	WEIGHT .53 LBS	PART NUMBER 3318	REV