

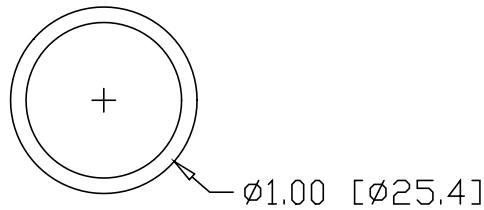

REV
SH
DWG NO 7807

REVISIONS			
REV	DESCRIPTION	DATE	APPROVED

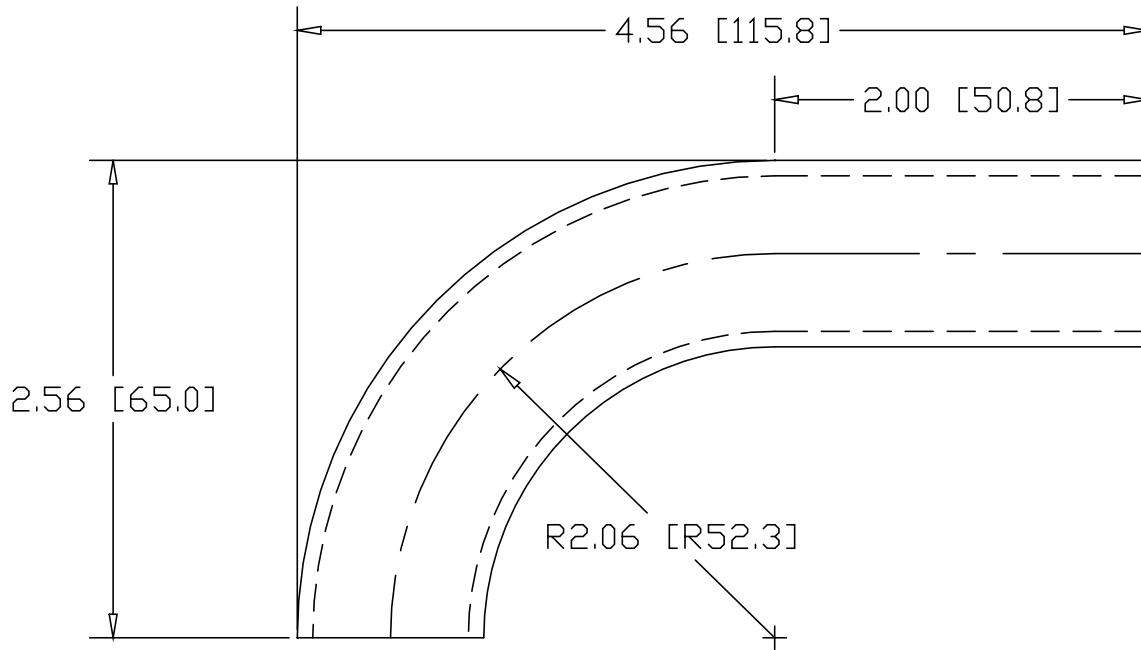

INCHES [MILLIMETERS]

ALTERNATE MATERIAL	PART NUMBER
1.00" OD X .125W (6061-T1) ALUMINUM TUBE	7823
1.00" OD X .083W (304) STAINLESS STEEL TUBE	7839

PART NAME 1.00" OD TUBE 90° ELL X 2.06" CLR W/(1) 2" TANGENT			
MATERIAL 1.00" OD X .083W STEEL TUBE ASTM A513			
DATE 8/10/00		R & B WAGNER, INC.	
DRAWN BY RJF			
FINISH MILL		SIZE A	WEIGHT .36 LBS
			REV