

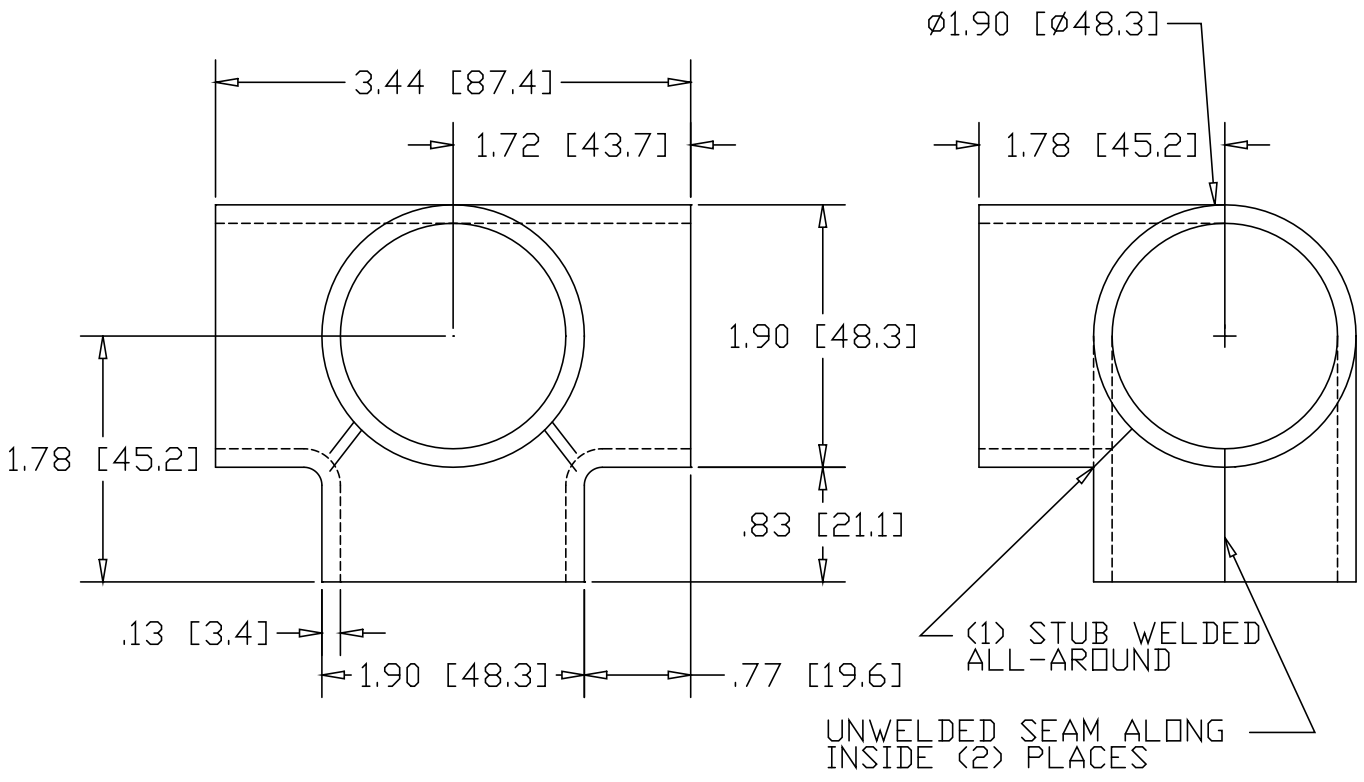

REV
SH
869
DWG NO

REVISIONS			
REV	DESCRIPTION	DATE	APPROVED



INCHES [MILLIMETERS]

PART NAME 1-1/2" PIPE SIZE FLUSH WELD SIDE OUTLET TEE			
MATERIAL 10 GA. HRP&D STEEL ASTM A569			
DATE 6/14/95		 R & B WAGNER, INC.	
DRAWN BY RJF			
FINISH MILL		SIZE A	WEIGHT 1.12 LBS
		PART NUMBER 869	REV