

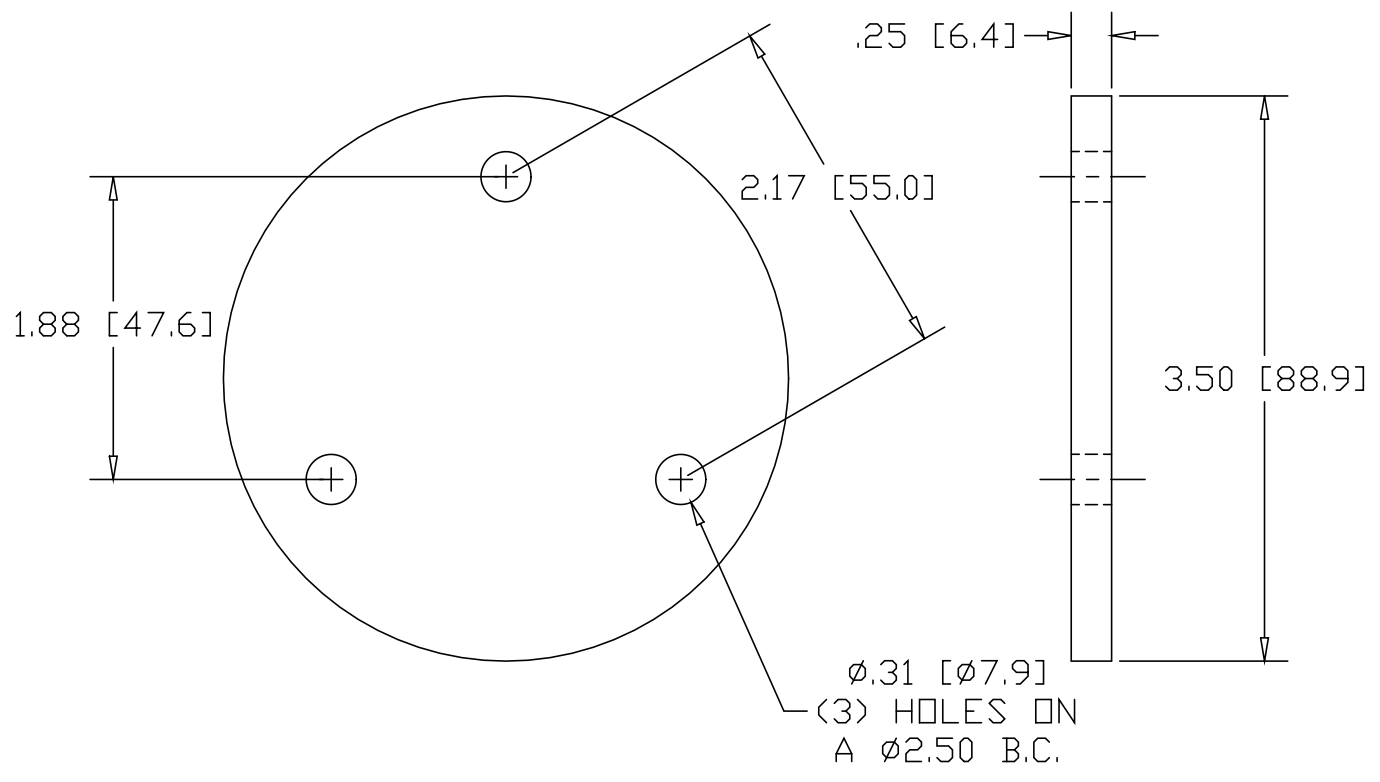

REV
SH
D173H
DWG NO

REVISIONS			
REV	DESCRIPTION	DATE	APPROVED



INCHES [MILLIMETERS]

ALTERNATE MATERIAL	PART NUMBER
.250 (3003) ALUMINUM ASTM B209	D174H
.250 (304) STAINLESS STEEL ASTM A240	D175H

PART NAME		3.50" BASE DISK WITH (3) MTG HOLES					
MATERIAL		.250 HRP&D STEEL ASTM A569					
DATE	11/20/98	 THE WAGNER COMPANIES R & B WAGNER, INC. AND J. G. BRAUN CO.					
DRAWN BY	RJF						
FINISH	MILL						
SIZE	A	WEIGHT	.64 LBS	PART NUMBER	D173H	REV	