

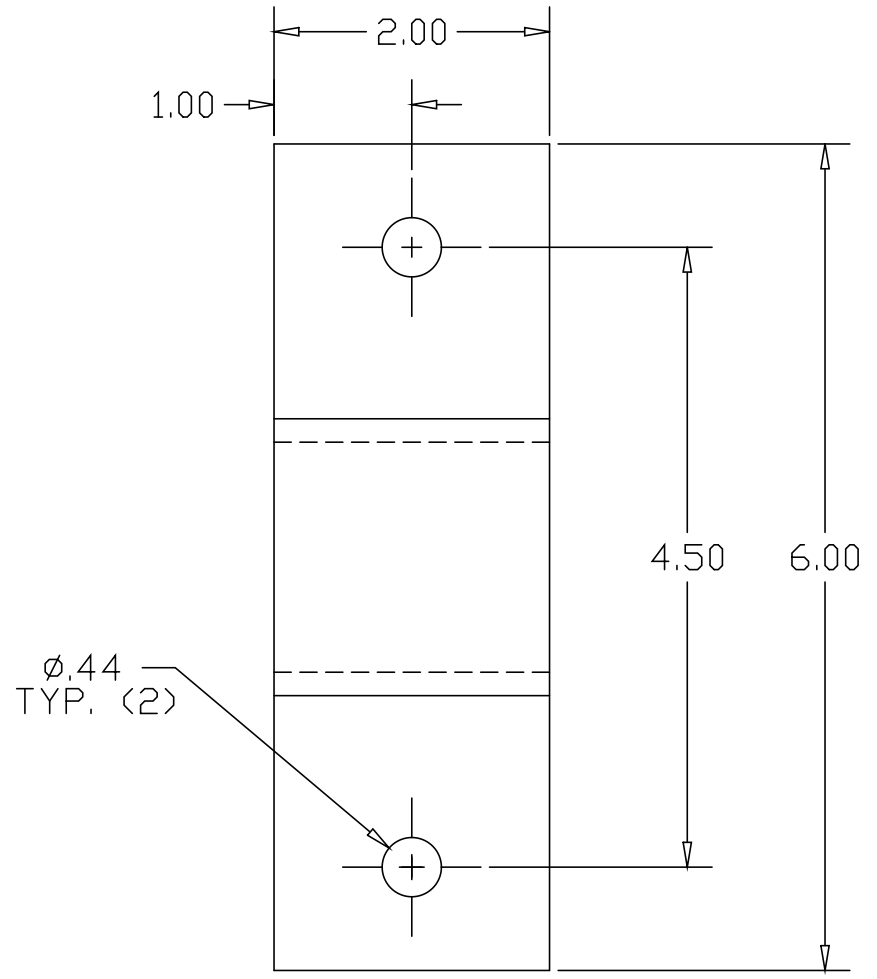

REVISIONS			
REV	DESCRIPTION	DATE	APPROVED

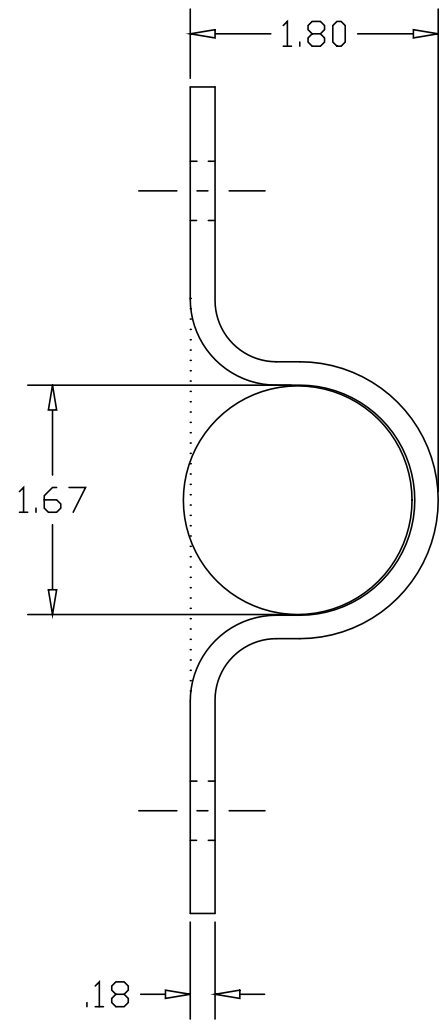

PART NAME		1-1/4" PIPE SIZE FACIA POST BRACKET					
MATERIAL		7 GA. STAINLESS STEEL ASTM A240					
DATE	6/16/94		THE WAGNER COMPANIES R & B WAGNER, INC. AND J. G. BRAUN CO.				
DRAWN BY	RJF						
FINISH	MILL						
SIZE	A	WEIGHT	.52 LBS	PART NUMBER	3762-SS	REV	