

REV
SH
5606
DWG NO

REVISIONS			
REV	DESCRIPTION	DATE	APPROVED

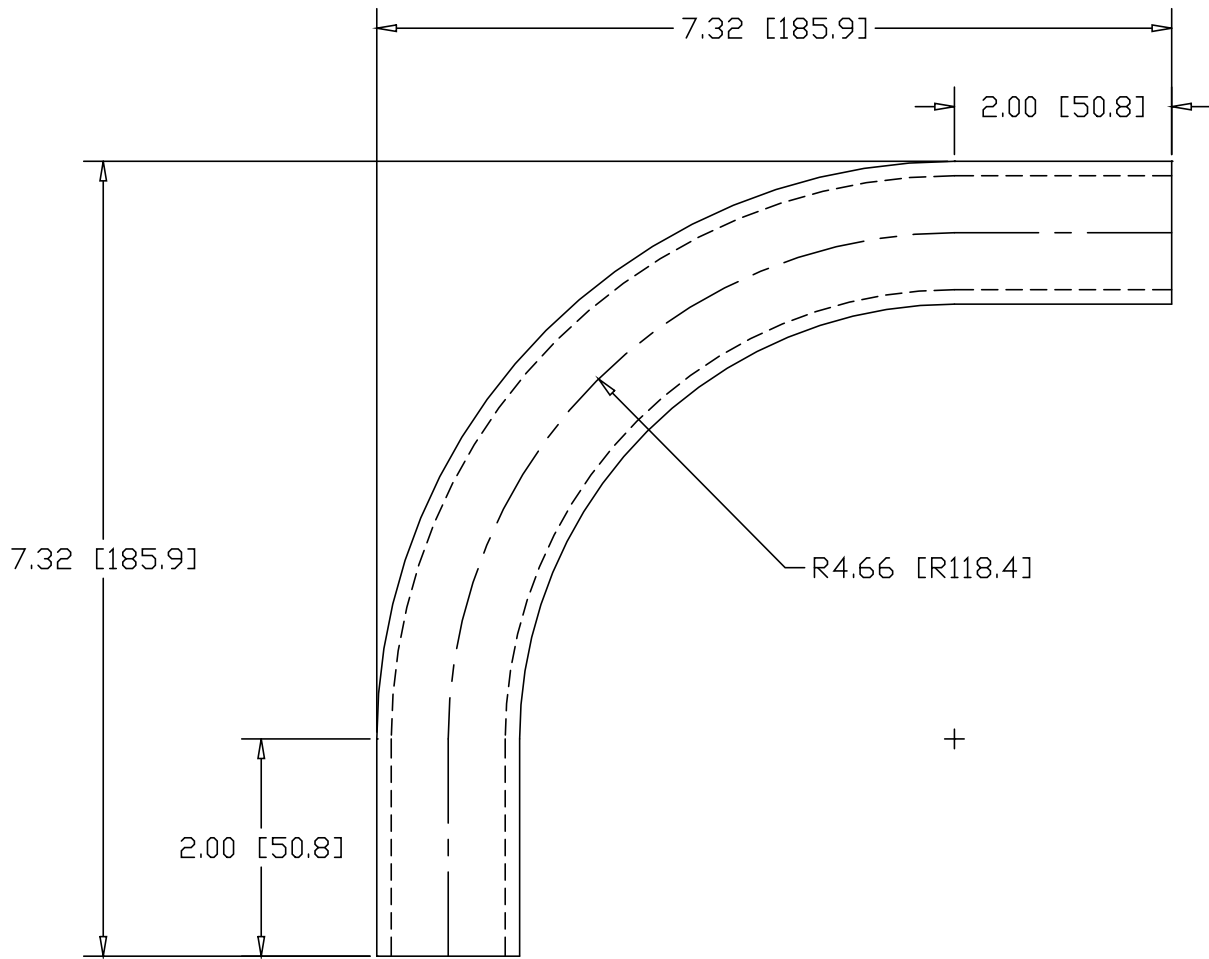

INCHES [MILLIMETERS]

ALTERNATE MATERIAL	PART NUMBER
1" SCH 40 (6063) ALUMINUM PIPE	5617
1" SCH 40 (304) STAINLESS STEEL PIPE	5626

PART NAME 1" PIPE SIZE 90° ELL X 4" I.R. W/ (2) 2" TANGENTS			
MATERIAL 1" SCH 40 A53 STEEL PIPE			
DATE 4/5/96	WAGNER	R & B WAGNER, INC.	
DRAWN BY RJF			
FINISH MILL			
SIZE A	WEIGHT 1.58 LBS	PART NUMBER 5606	REV