

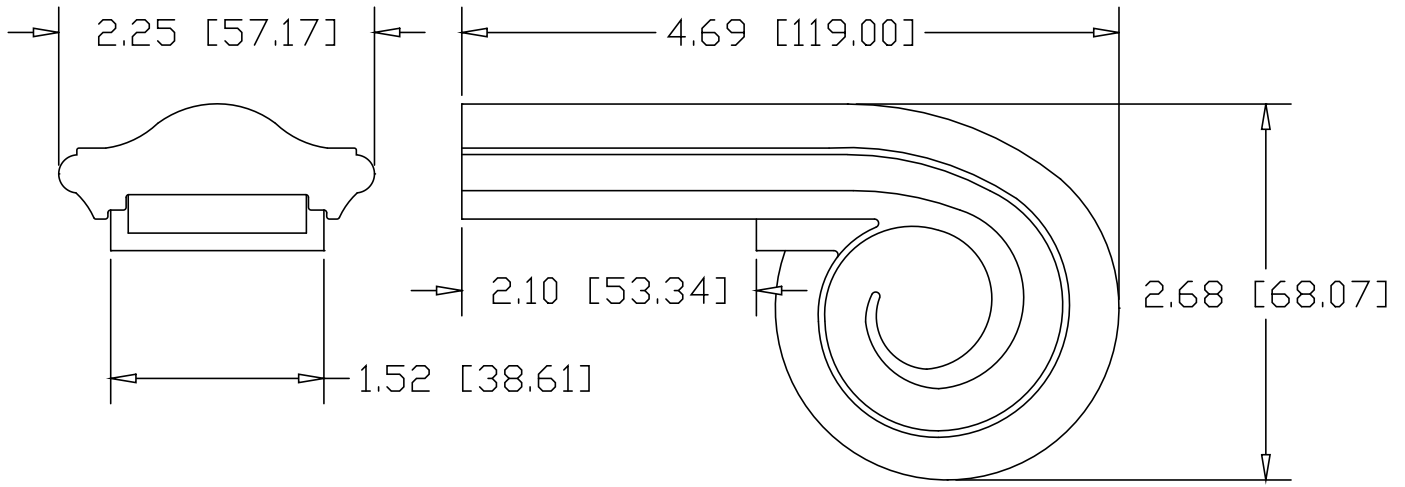

REV
SH
H1244G
DWG NO

REVISIONS			
REV	DESCRIPTION	DATE	APPROVED



INCHES [MILLIMETERS]

PART NAME		VOLUTE TERMINAL END FOR H1244					
MATERIAL		CAST MALLEABLE IRON ASTM A47					
DATE	07/15/11	 THE WAGNER COMPANIES R & B WAGNER, INC. AND J. G. BRAUN CO.					
DRAWN BY	RJF						
FINISH	SHOT BLASTED						
SIZE	A	WEIGHT	1.77 LBS	PART NUMBER	H1244G	REV	