

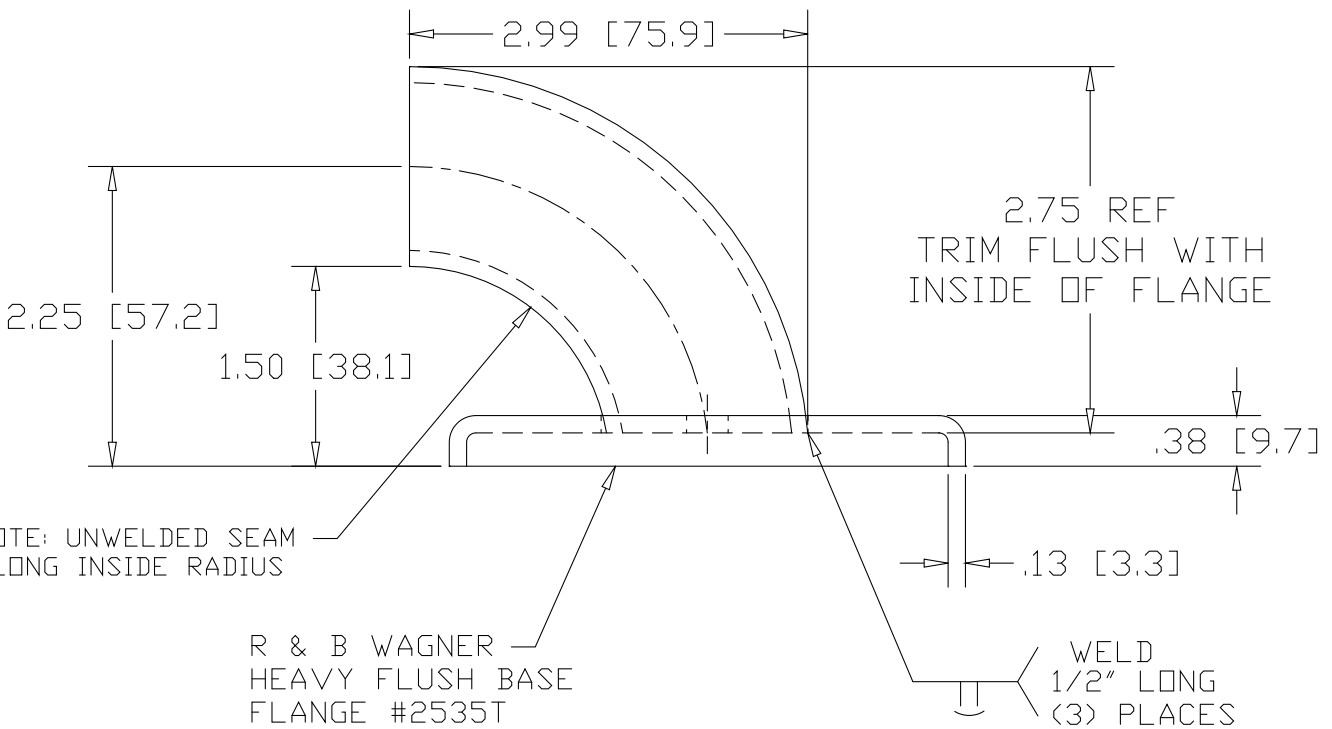

REV
SH
1150-2
DWG NO

REVISIONS			
REV	DESCRIPTION	DATE	APPROVED

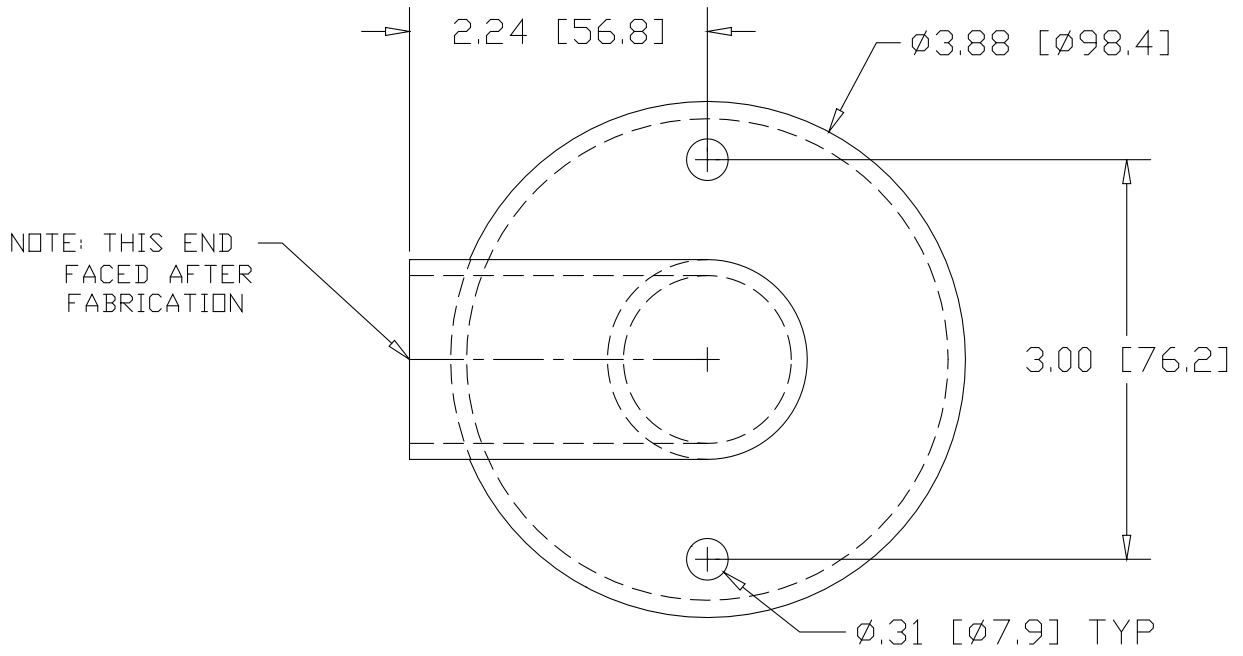

INCHES [MILLIMETERS]

PART NAME 1.50" TUBE SIZE X 2.25CL WALL RETURN W/2 HOLES			
MATERIAL ASTM A569 - STEEL			
DATE 12/30/02	 THE WAGNER COMPANIES R & B WAGNER, INC. AND J. G. BRAUN CO.		
DRAWN BY RJF			
FINISH MILL		SIZE A	WEIGHT 1.0 LBS.
			REV