

TEST SAMPLE DESCRIPTION

Wagner Part Number: GRS6545SS

1.1 General

Product Code/Name	S6545S-12
Test Requirements	STRUCTURAL PERFORMANCE (A) E2353-16 E2358-17
Date of Test	19/09/2019

1.2 Barrier/Glass

Glass Make Up	12mm Toughened Glass
Glass Panel Size	Height - 1100mm Width - 1200mm
Overall Size	Height - 1142mm Width - 1200mm
Handrail Used	No Handrail

1.3 Spigot System: S6545S

Material	Stainless Steel 2205 Duplex
Overall Size	147mmH x 65mmL x 45mmW
Drawing Supplied	Yes
Fixing Method	M10 316 stainless steel bolt

PRODUCT TEST REPORT

Wagner Part Number: GRS6545SS

PTY LTD

DATE: 18/09/2019		PRODUCT NUMBER: S6545S		HAND RAIL TYPE: N/A	
GLASS TYPE	12mm Toughened Glass				
GLASS SIZE	1100mmHx1200mmW				
TEST METHOD	Concentrated, Uniform, Infill, loading applied with hydraulic ram				
FIXING TYPE, CENTRES	Spigots were 240mm in from each end (20%)				
TEMPERATURE	20.6°C				
HUMIDITY	59%				
RESULTS					
Type	Structural Performance	Deflection	Residual	Time U/L	
I-III	Concentrated Load on Rail: 890N Uniform Linear Load on Rail: 290N/m Infill Horizontal Load: 220N				
I-IV	Concentrated Load on Rail: 890N Uniform Linear Load on Rail: 730N/m Infill Horizontal Load: 220N				
I-V	Concentrated Load on Rail: 1330N Uniform Linear Load on Rail: 730N/m Infill Horizontal Load: 220N	77.2mm	3.31mm	60sec	
		44.79mm	1.61mm	60sec	
		8.1mm	0mm	60sec	
I-VI	Concentrated Load on Rail: 1620N Uniform Linear Load on Rail: 880N/m Infill Horizontal Load: 220N				
Notes:					
<p>The Uniform Linear Load was multiplied by 1.2 as we tested with a 1200mm wide panel of glass. The total loading for this test was 730N x 1.2 = 876N</p>					

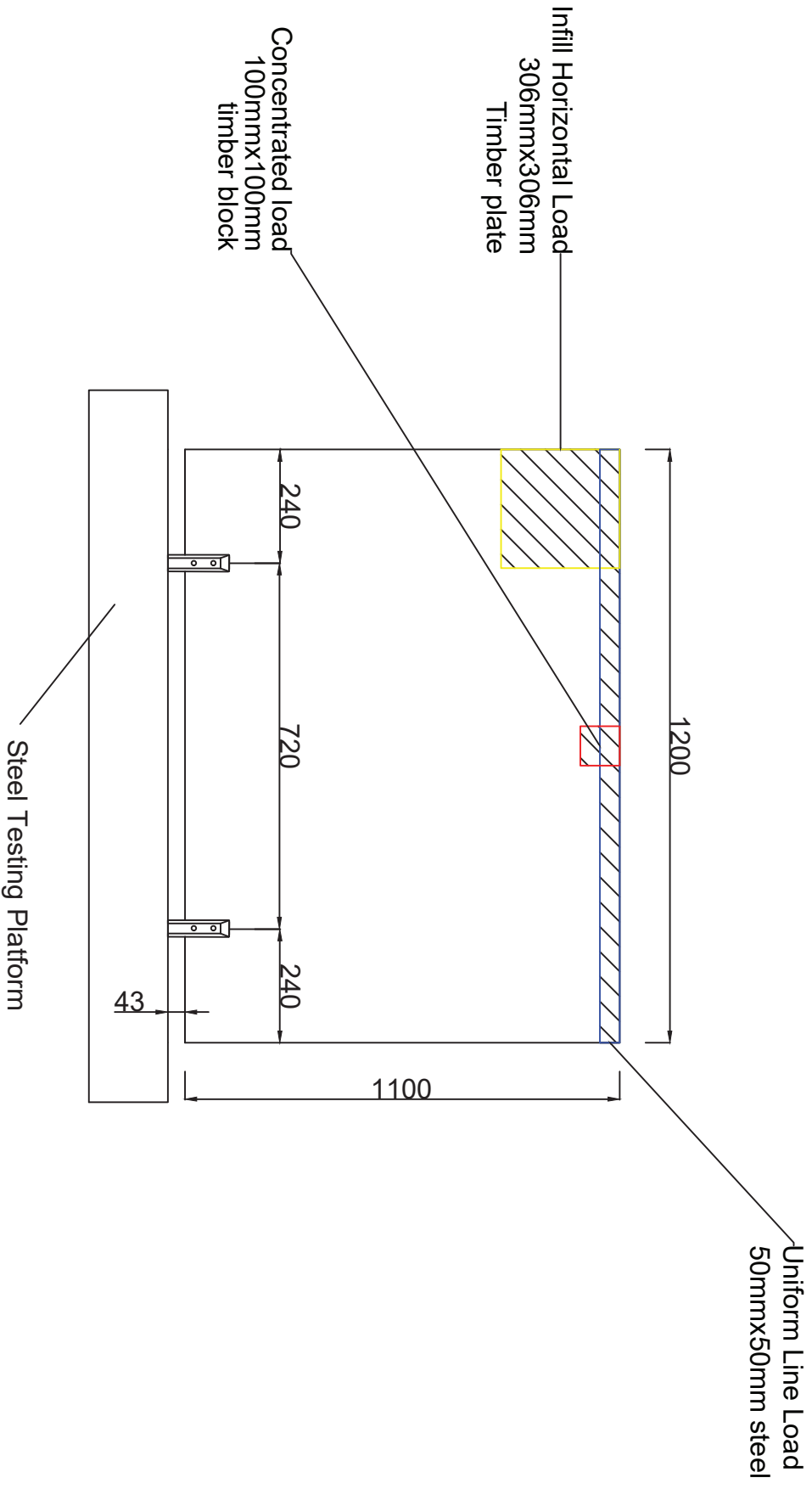

Part no: S6545S Glass Type: 12mm Toughened Glass

Material: 2205 Duplex Scale:

Fasteners used for testing: 316L SS M10 Bolts

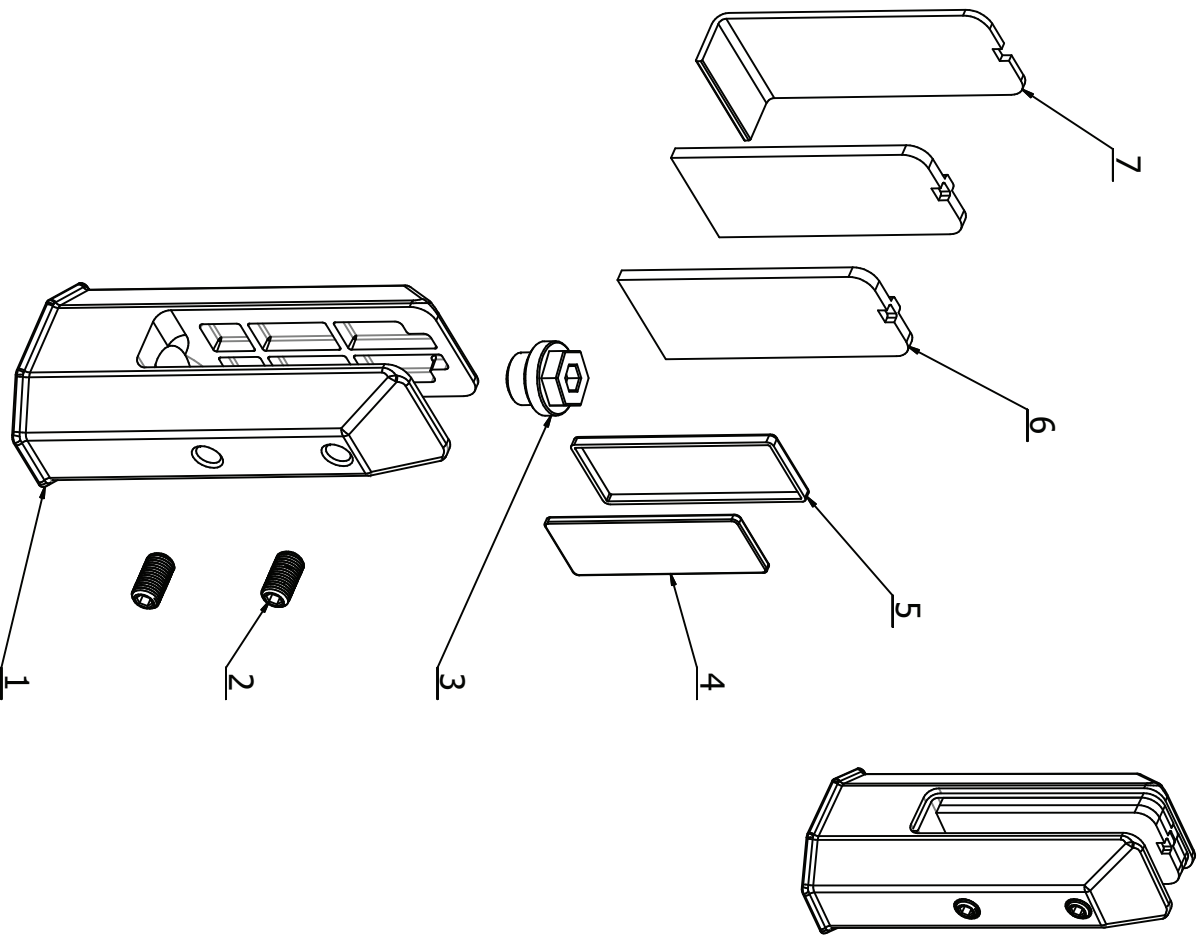

BILL OF MATERIALS			
ITEM	PART NO.	DESCRIPTION	QTY.
1	S6545S	SPIGOT BODY	1
2	M10x18	GRUB SCREW	2
3	TLSF82-SN	MOUNTING NUT	1
4	SS48-AP	GLASS CLAMP PLATE	1
5	S6545-PP	GLASS CLAMP PAD	1
6	S6545PI	SHIM GASKET	OPTIONAL
7	S6545PL	ISOLATOR	1

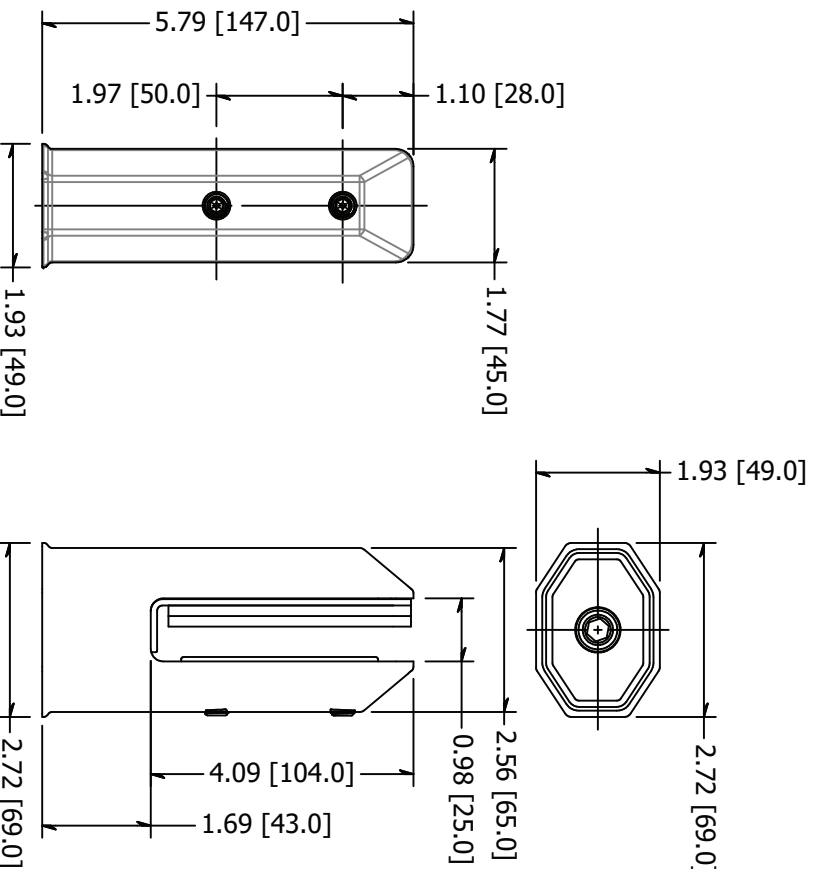

MATERIAL:
2205 SSTL

FINISH:
#4

DATE:
11/8/2019

SCALE:
REV:

DESCRIPTION:
Spigot, Center Concealed, For 10-24.52mm Glass, 5.8" High by 2.5" Wide

WEIGHT:

ITEM NUMBER:
GRS6545SS



2

1