

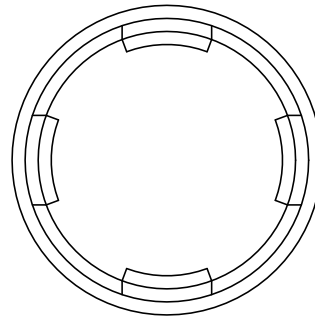

REV  
SH  
DWG NO 3211-H

REVISIONS			
REV	DESCRIPTION	DATE	APPROVED

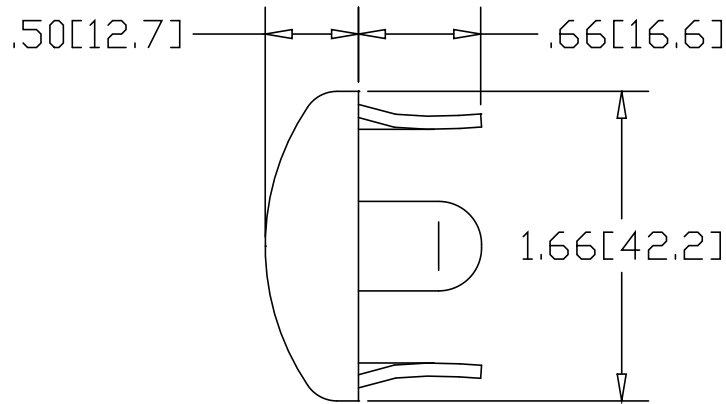
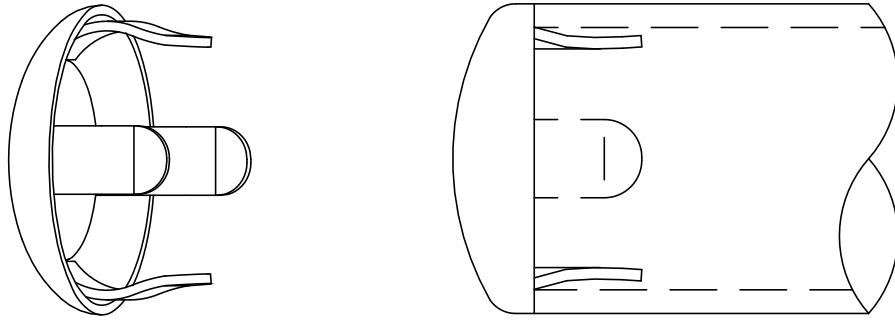

INCHES [MILLIMETERS]

ALTERNATE MATERIAL	PART NUMBER
.063 (3003) ALUMINUM ASTM B-209	3211-AH
16 GA. (304) STAINLESS STEEL ASTM A240	3211-SS

PART NAME 1-1/4" SCH 40 PIPE TYPE "H" DRIVE-ON END CAP			
MATERIAL 16 GA. HRP&D STEEL ASTM A-569			
DATE 3/28/95		R & B WAGNER, INC.	
DRAWN BY RJF		FINISH MILL	SIZE A
		PART NUMBER 3211-H	REV