

REV
SH
8902
DWG NO

REVISIONS			
REV	DESCRIPTION	DATE	APPROVED

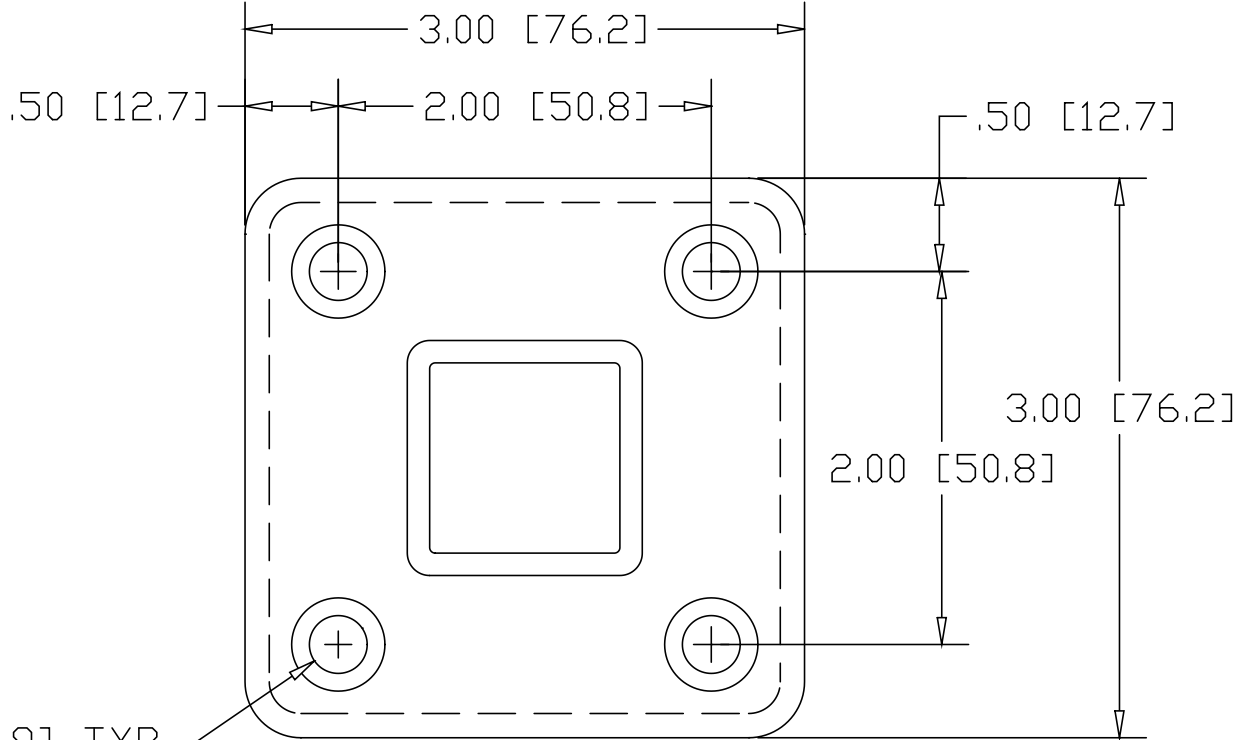

∅.31 [∅7.9] TYP WITH C'SINK

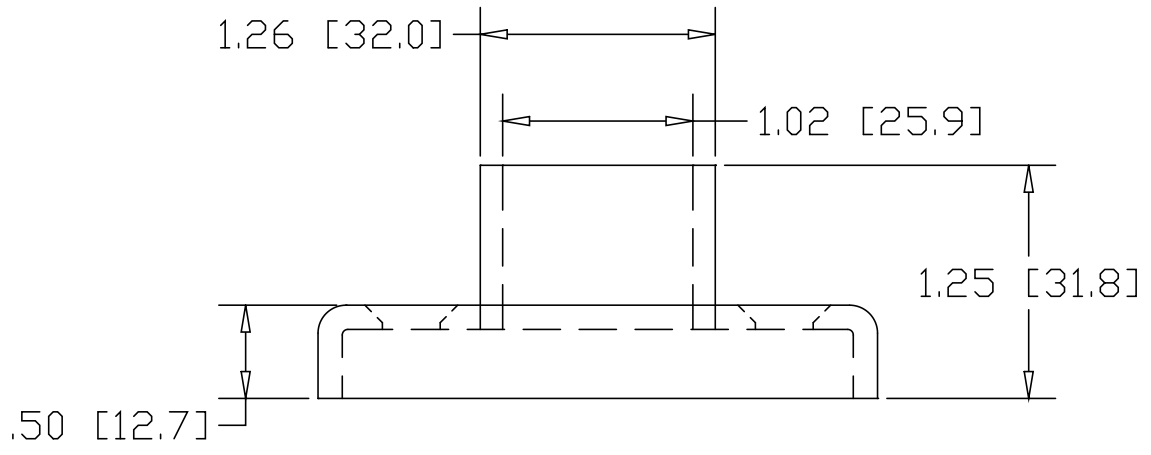

INCHES [MILLIMETERS]

*USE WITH ANCHOR PLATE #8706 IN STEEL AND #8776 IN ALUM.

ALTERNATE MATERIAL	PART NUMBER
.125 (3003) ALUMINUM ASTM B209	8926

PART NAME		1" SQ. TUBE SOCKET FLANGE W/⟨4⟩ HOLES					
MATERIAL		10 GA. HRP&D STEEL ASTM A569					
DATE	1/15/93	 THE WAGNER COMPANIES R & B WAGNER, INC. AND J. G. BRAUN CO.					
DRAWN BY	RJF						
FINISH	MILL						
SIZE	A	WEIGHT	.51 LBS	PART NUMBER	8902	REV	