

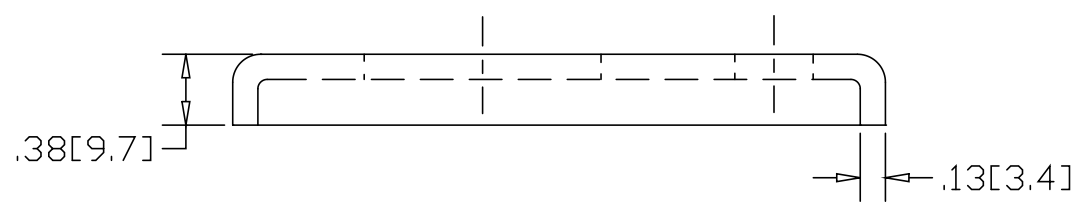

REV
SH
DWG NO 2526RT

REVISIONS			
REV	DESCRIPTION	DATE	APPROVED

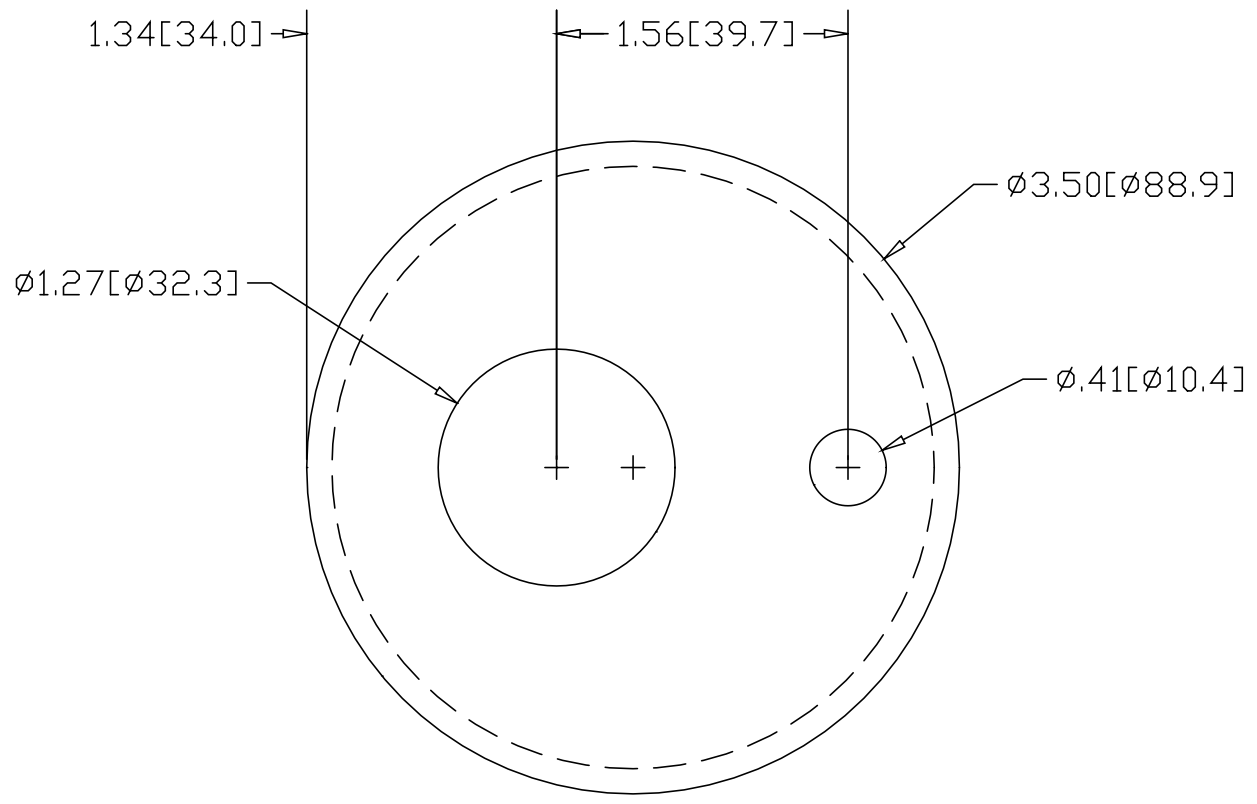

INCHES [MILLIMETERS]

ALTERNATE MATERIAL	PART NUMBER
.125 (3003) ALUMINUM ASTM B209	2566RT
10 GA. (304) STAINLESS STEEL ASTM A240	2606RT

PART NAME		1.25" OD TUBE SIZE HFB OFFSET FLANGE					
MATERIAL		10 GA. HRP&D STEEL ASTM A569					
DATE	4/5/99	 R & B WAGNER, INC.					
DRAWN BY	RJF						
FINISH	MILL						
SIZE	A	WEIGHT	.41 LBS	PART NUMBER	2526RT	REV	