

REV
SH
DWG NO 7713B

REVISIONS			
REV	DESCRIPTION	DATE	APPROVED

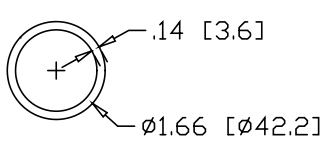
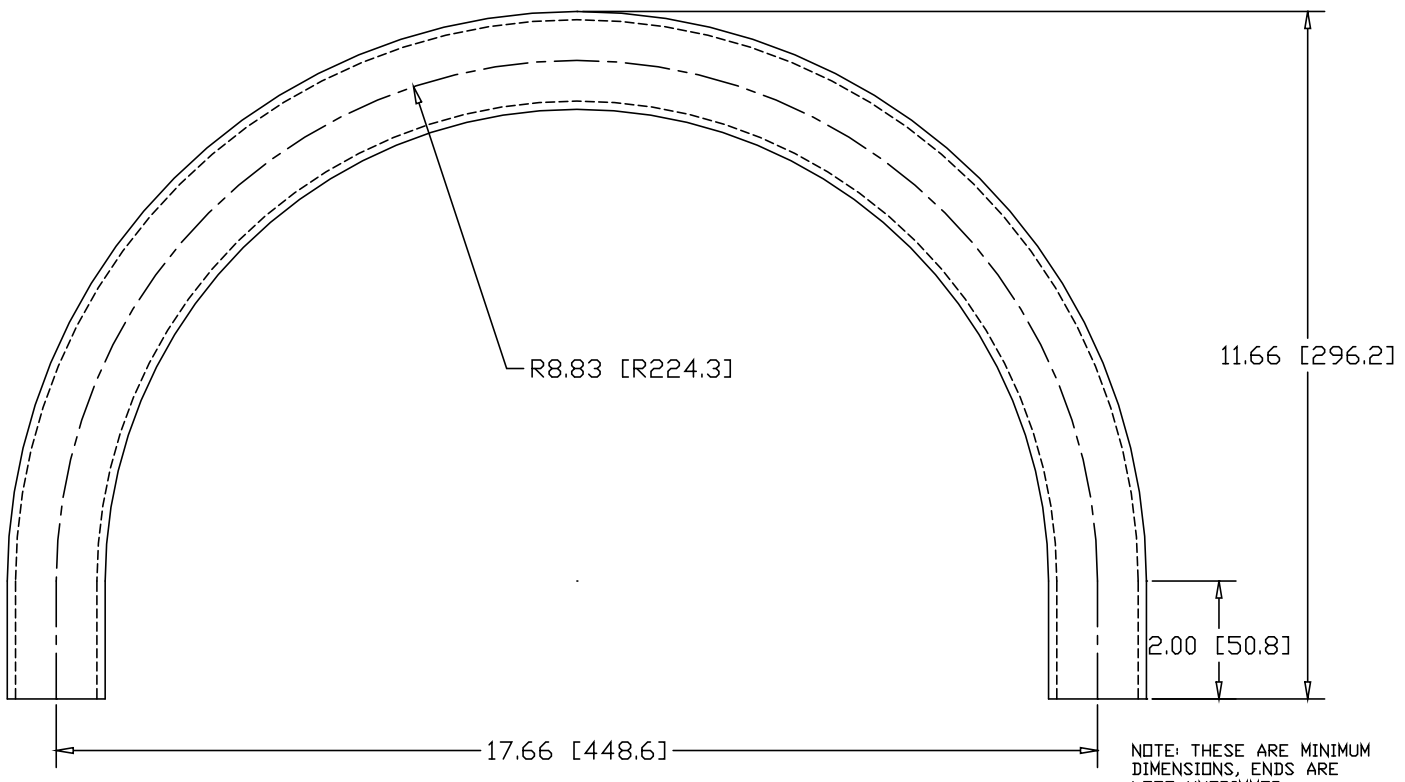

INCHES [MILLIMETERS]

ALTERNATE MATERIAL	PART NUMBER
1-1/4" SCH 40 (6063) ALUMINUM PIPE	7727B
1-1/4" SCH 40 (304) STAINLESS STEEL PIPE	7741B

PART NAME 1-1/4" PIPE SIZE 180° ELL X 8" I.R. W/ (2) 2" TANGENTS			
MATERIAL 1-1/4" SCH 40 A53 STEEL PIPE			
DATE 7/18/01	WAGNER	R & B WAGNER, INC.	
DRAWN BY JAH			
FINISH MILL			
SIZE A	WEIGHT 6.00 LBS	PART NUMBER 7713B	REV