

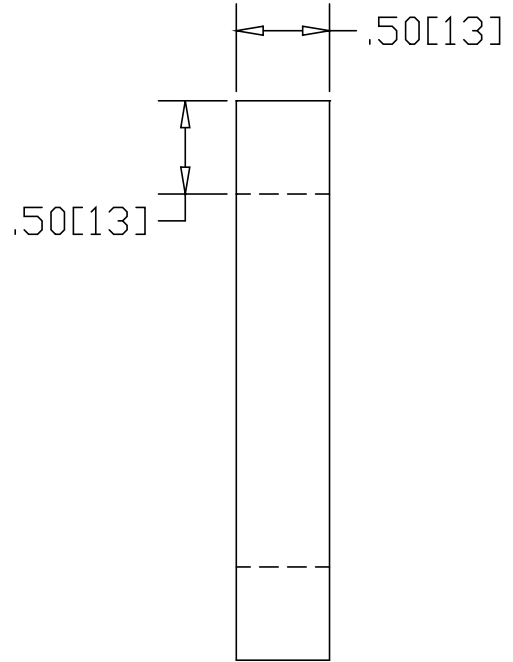

REV
SH
4382
DWG NO

REVISIONS			
REV	DESCRIPTION	DATE	APPROVED

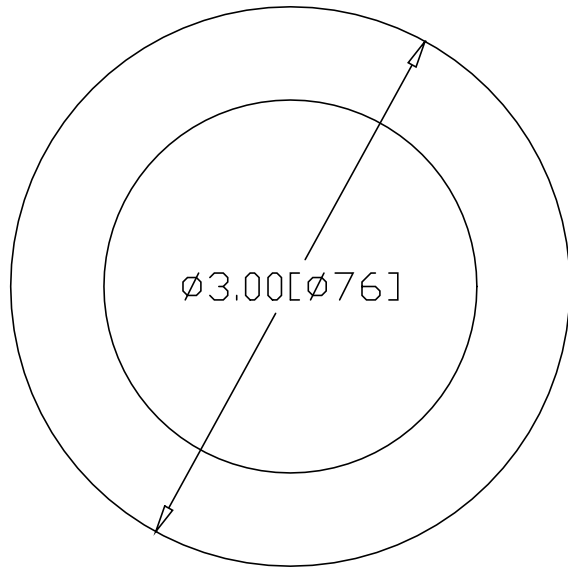

INCHES [MILLIMETERS]

ALTERNATE MATERIAL	PART NUMBER
3.00" OD X .50 WALL (6063) ALUMINUM TUBE	4383

PART NAME		.50" SQUARE X 3.00" OUTSIDE DIAMETER RING			
MATERIAL		3.00" OD X .50 WALL STEEL TUBE			
DATE	7/3/96	 THE WAGNER COMPANIES R & B WAGNER, INC. AND J. G. BRAUN CO.			
DRAWN BY	RJF				
FINISH	SAWCUT TUMBLE DEBUR	SIZE	WEIGHT	PART NUMBER	REV
		A	.56 LBS	4382	